



**MCWANE**  
PLANT & INDUSTRIAL



**KENNEDY VALVE**

# GRAVITY / PLAIN SWING CHECK VALVE SIZES 2" - 12"

DRAWING NO. - 54241 REV - 01

DRAWN BY - L2C

No.	DATE	ECN	REVISION
1			Release for use with 1106 valve.

DIMENSIONS						
	DA LG	FLG THK	FLG DD	DA HT	COVER DD	WALL THK
SIZE	A	B	C	D	E	J
2	8	0.66	6	6	6	0.34
2 ½	8.5	0.72	7	6.44	7	0.41
3	9.5	0.78	7.5	6.85	7.5	0.44
4	11.5	1.00	9	8.69	9	0.50
6	14	1.06	11	10.51	11	0.62
8	19.5	1.25	13.5	12.56	13.5	0.75
10	24.5	1.31	16	14.07	16.75	0.81
12	27.5	1.38	19	16.13	19	0.88

**NOTES:**

- Standard syntax for a standard check valve is:  
161XXXX1106 (brass to brass) or  
161XXXX1106A (resilient to brass), where XXXX signifies the size.
- A special "Buy America" valve can be obtained by specifying "DOM" after the standard number.

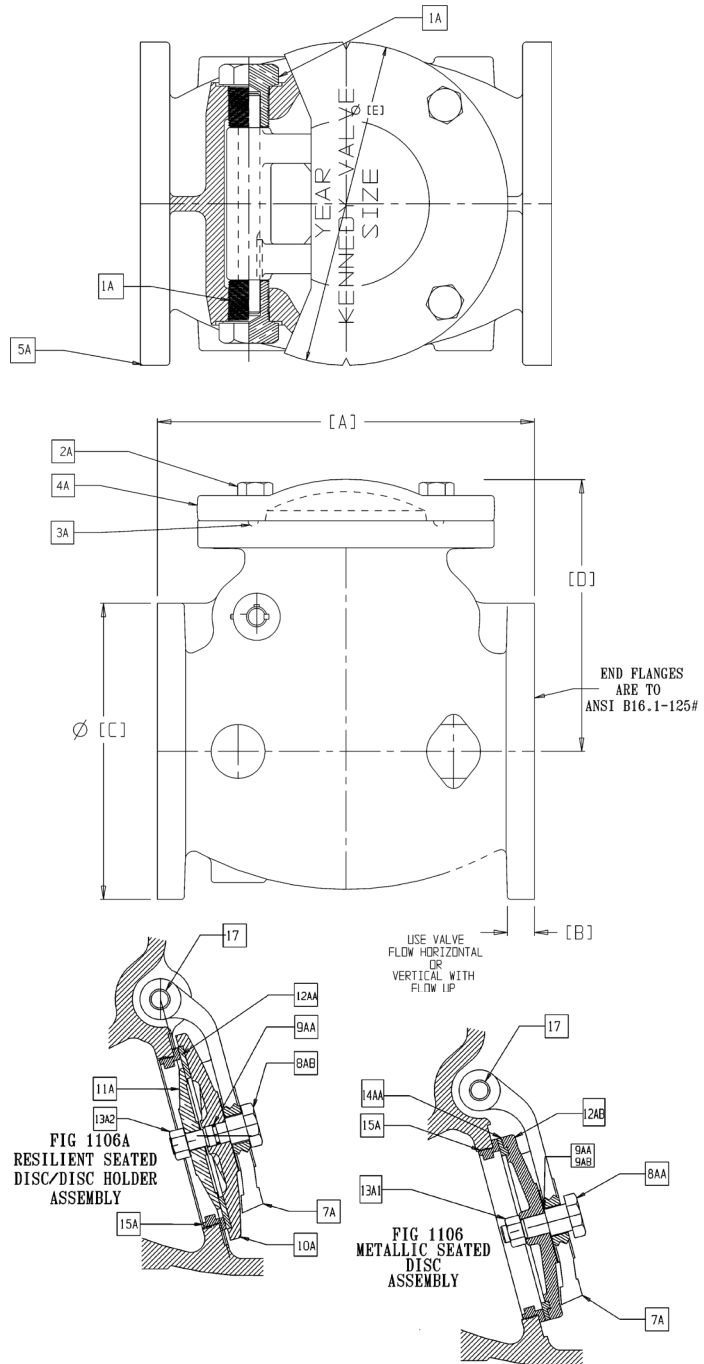

PARTS LIST		
PART No.	PART	MATERIAL & ASTM DESIGNATION
1A	Side Plug	Bronze B371 C69300
2A	Hex Bolt	SS18-8
3A	O-ring Seal Cover to Body	Buna-N
4A	Check Valve Cap	Gray, Cast Iron ASTM A 126B
5A	Body	Gray, Cast Iron
7A	Hinge	Bronze (2"-3") / D.I. (4"-12")
8AA	Disc Bolt - Fig. 1106 (Metal to Metal)	Steel (4"-8") / Bronze (10" & 12")
8AB	Disc Bolt - Fig. 1106A (Resilient)	Bronze (4"-12")
9AA	Disc Bolt O-ring	Buna-N (10" & 12")
9AB	Disc Bolt Gasket	Fibre (4"-8")
10A	Disc Holder - Fig. 1106A	Gray, Cast Iron (4"-12", exc. 8")
10A	Disc Holder with Integral Bolt	Bronze (2"-3")
11A	Disc Plate - Fig. 1106A	Bronze
12AA	Replacable Rubber Disc - Fig. 1106A	Rubber
12AB	Disc with Integral Bronze Ring - Fig. 1106	Gray, Cast Iron (4"-12")
12AB	Disc with Integral Bolt and Ring - Fig. 1106	Bronze (2"-3")
13A1	Hex Nut-Disc - Fig. 1106	SS18-8 (2"-12")
13A2	Hex Nut-Disc Holder - Fig. 1106A	SS18-8 (2"-3")
14AA	Disc Ring Integral with Disc - Fig. 1106	Bronze (4" 12")
15A	Seat Ring	Bronze B584 C89833 / C87850
17	Hinge Pin	Stainless Steel SS A-276 (304)