

ITEM #	DESCRIPTION	MATERIAL
1A	VALVE BODY	DUCTILE IRON, ASTM A-536, Grade 70-50-05
1B	BODY RING (Permanently Attached)	304 STAINLESS STEEL
1C	BODY O-RING (Permanently Attached)	BUNA-N
2	VANE	DUCTILE IRON, ASTM A-536, Grade 70-50-05
3	END COVER PLATE	DUCTILE IRON, ASTM A-536, Grade 70-50-05
4	RUBBER VANE SEAT RING	EPDM
5	SEGMENTED CLAMP RING (4)	304 STAINLESS STEEL, ASTM A-276
6	SEALING WASHER	NYLON
7	SHAFT SLEEVE BEARING	FIBERGLIDE BACKED WITH STAINLESS STEEL
8	SHAFT O-RING CARTRIDGE	BRONZE
9	O-RING SHAFT SEALS (2)	BUNA-N
10	OUTSIDE O-RING CARTRIDGE SEAL	BUNA-N
11	END COVER PLATE HEX BOLTS	STEEL, ASTM A-307, ELECTRO ZINC PLATED
12	FLAT HEAD SOCKET SCREW (For Rubber Vane Seat Ring)	18-8 STAINLESS STEEL (WITH LOCTITE)
13	FLAT HEAD SOCKET SCREW (For Thrust Bearing)	18-8 STAINLESS STEEL (WITH NYLON INSERT)
14	ALLEN HEAD SET SCREW (For Thrust Bearing)	18-8 STAINLESS STEEL (WITH NYLON INSERT)
15	END COVER PLATE O-RING	BUNA-N
16	THRUST BEARING	BRONZE
17	TAPER PIN (3)	416 STAINLESS STEEL
18	TAPER PIN O-RING (3)	BUNA-N
19	TAPER PIN WASHER (3)	416 STAINLESS STEEL
20	TAPER PIN BOLT (3)	304 STAINLESS STEEL
21	SHAFT (OPERATOR)	304 STAINLESS STEEL
22	SHAFT (THRUST SIDE)	304 STAINLESS STEEL



KENNEDY VALVE

Division of McWane, Inc.
1021 EAST WATER STREET ELMIRA, NEW YORK 14901

DWN: MMR

DATE: 8/18/11

DWG. NO.
BFE-15-14AA

30" & 36" STYLE 1450
CLASS 150 BUTTERFLY VALVE
SUB-ASSEMBLY / MATERIAL LIST
(NON-ADJUSTABLE PACKING)
FLANGED ENDS

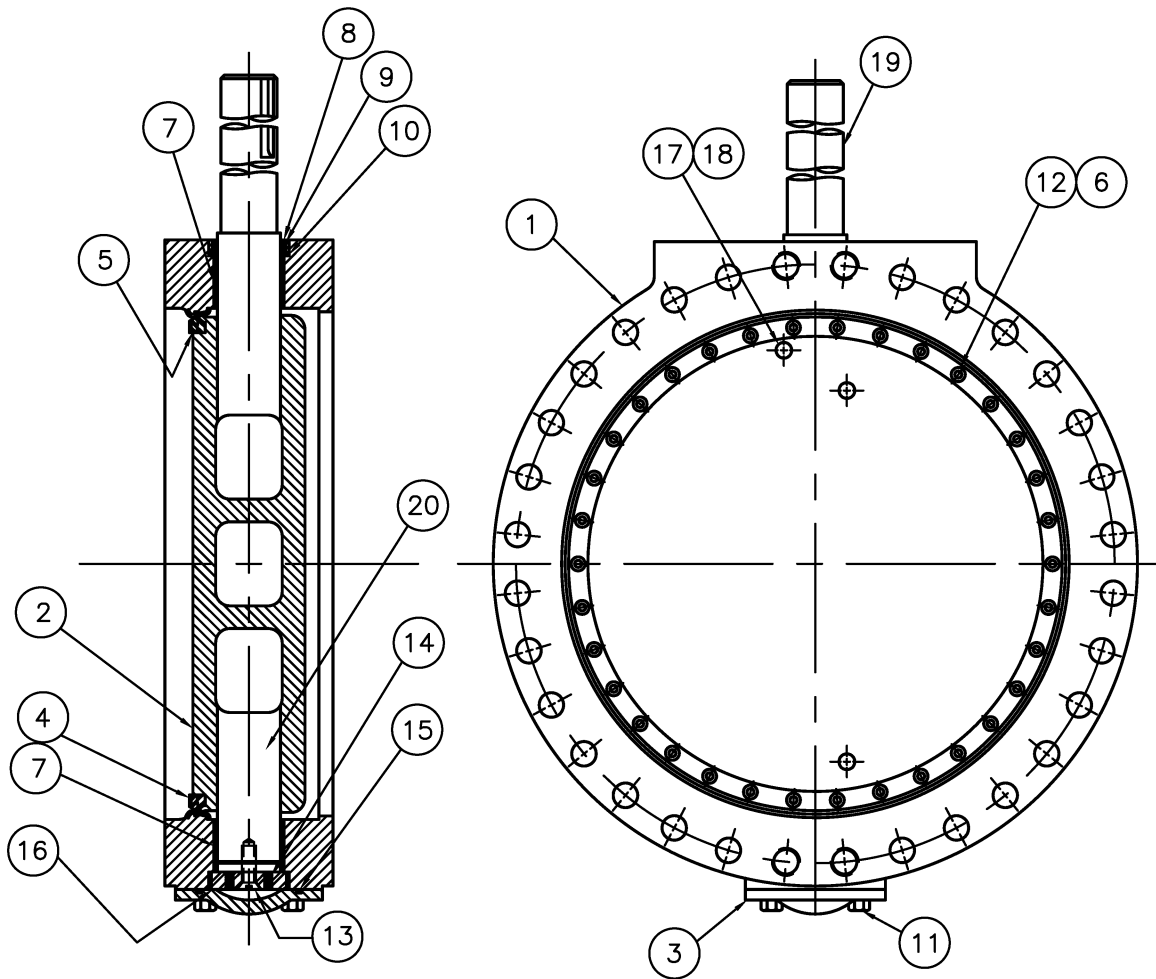

ITEM NO.	DESCRIPTION	MATERIAL
1	BODY, VALVE	DUCTILE IRON, ASTM A-536, GR. 70-50-05 W/304 STN. STL. SEAT
2	VANE	DUCTILE IRON, ASTM A-536 GR. 70-50-05
3	END COVER	DUCTILE IRON, ASTM A-536 GR. 70-50-05
4	SEAT RING, VANE	EPDM
5	CLAMP RING, SEAT	304 STAINLESS STEEL
6	SEALING WASHER	NYLON
7	BUSHING, BODY	FIBERGLIDE
8	CARTRIDGE, SHAFT	BRONZE
9	SEAL, SHAFT	BUNA-N
10	SEAL, CARTRIDGE	BUNA-N
11	BOLT, END COVER	COMMERCIAL STEEL
12	SOCKET SCREW ~ FLAT HEAD	18-8 STAINLESS STEEL W/NYLOK INSERT
13	SOCKET SCREW ~ FLAT HEAD	18-8 STAINLESS STEEL W/NYLOK INSERT
14	SET SCREW ~ FLAT POINT	18-8 STAINLESS STEEL W/NYLOK INSERT
15	END COVER SEAL	BUNA-N
16	THRUST BEARING PLATE	BRONZE
17	TAPER PIN	416 STAINLESS STEEL
18	TAPER PIN BOLT	18-8 STAINLESS STEEL
19	SHAFT (OPERATOR)	304 STAINLESS STEEL
20	SHAFT (THRUST)	304 STAINLESS STEEL



KENNEDY VALVE
 Division of McWane, Inc.
 1021 EAST WATER STREET ELMIRA, NEW YORK 14901

DWN: MMR
 DATE: 7/14/11
 DWG. NO.
 BFE-15-14AB

42" & 48" STYLE 1450
 CLASS 150 BUTTERFLY VALVE
 SUB-ASSEMBLY / MATERIAL LIST
 (NON-ADJUSTABLE PACKING)
 FLANGED ENDS

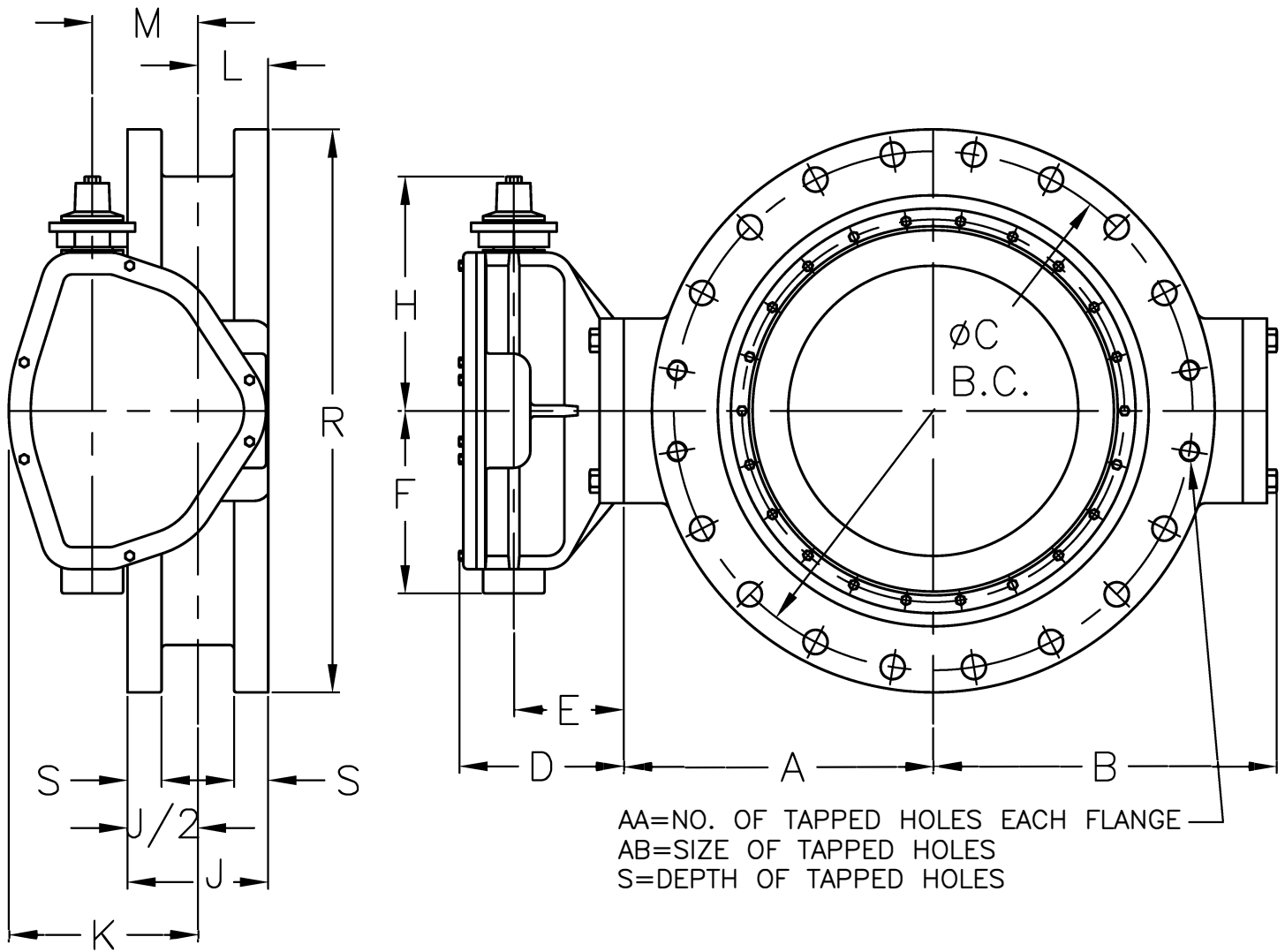

	OPERATOR MODEL	D	E	F	H	K	L	M	N
30" & 36"	2200	9 1/16	6 1/4	10 3/8	14 5/16	10 3/4	3 7/8	6	72
42"	4350	10 3/16	6 1/16	14 5/16	18	13 5/16	4 3/16	7 1/2	90

VALVE SIZE	A	B	C	J	P	Q	R	S	AA	AB	WEIGHT
30"	20.625	21.50	36	12	28	1.250	38.750	2.125	4	1.250-7	1790
36"	24.250	25.06	42.750	12	32	1.500	46	2.375	4	1.500-6	2515
42"	28.250	28.88	49.500	12	36	1.500	53	2.625	4	1.500-6	4405

NOTE 1: FLOW MAY BE IN EITHER DIRECTION

NOTE 2: VALVE SHAFT WILL MEET OR EXCEED REQUIREMENTS OF SHAFT TABLE PER AWWA STANDARD C-504 FOR APPLICABLE CLASS.

NOTE 3: REFERENCE AWWA C-504 FLANGES & DRILLING (A.N.S.I. 125)

NOTE 4: "N" = NUMBER OF TURNS TO CLOSE

NOTE 5: "P" = NUMBER OF BOLTS ON EACH FLANGE

NOTE 6: "Q" = DIAMETER OF BOLTS

NOTE 7: OPERATED BY 2" AWWA OPERATING / WRENCH NUT



KENNEDY VALVE

Division of McWane, Inc.
 1021 EAST WATER STREET ELMIRA, NEW YORK 14901

DWN: TRIJ
 DATE: 1/1/11
 DWG. NO.
 BFE-15-14B

30" THRU 42" STYLE 1450
 CLASS 150 BUTTERFLY VALVE
 BURIED OPERATOR
 FLANGED ENDS

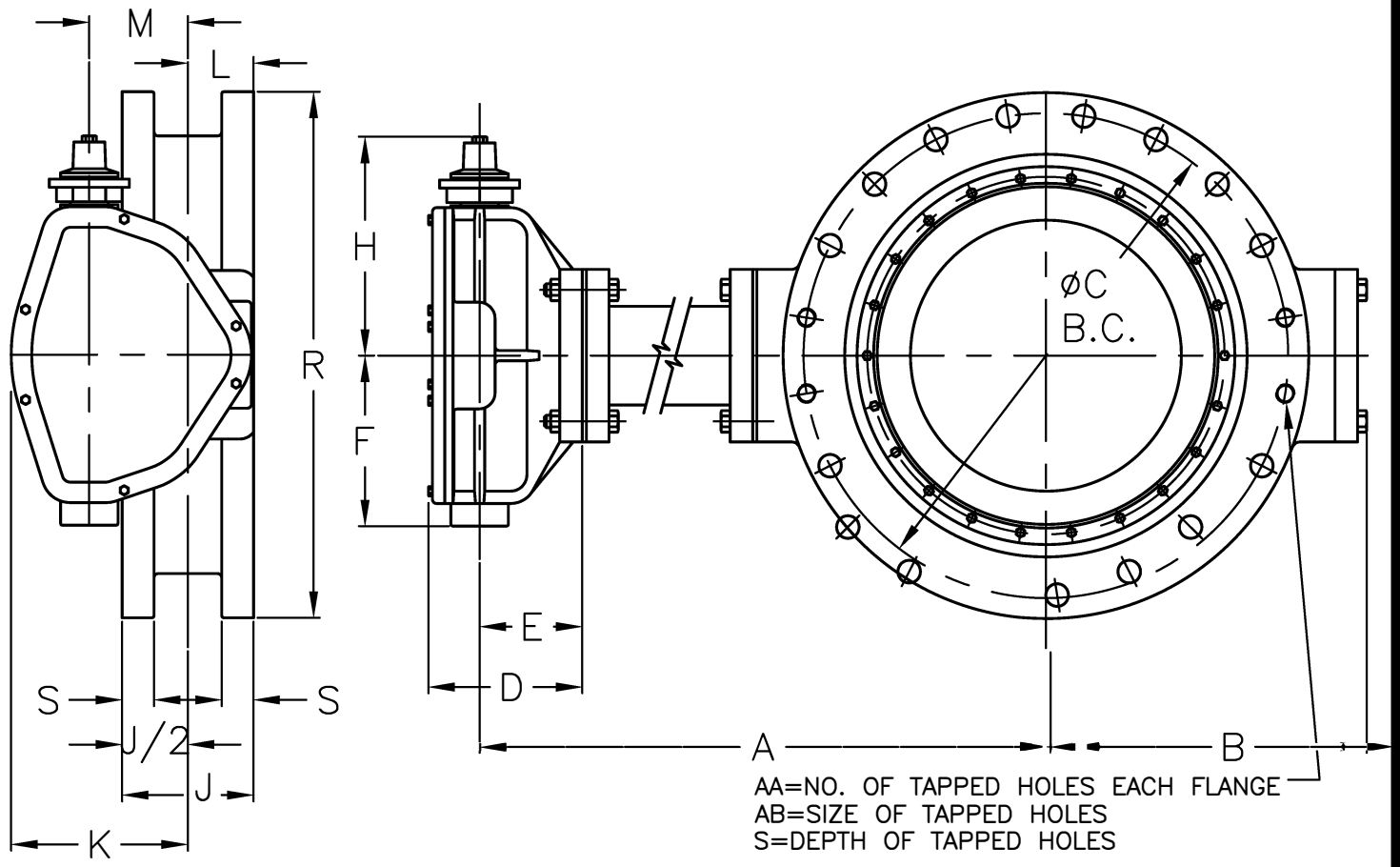

	OPERATOR MODEL	D	E	F	H	K	L	M	N
30" & 36"	2200	9 1/16	6 1/4	10 3/8	14 5/16	10 3/4	3 7/8	6	72
42"	4350	10 3/16	6 1/16	14 5/16	18	13 5/16	4 3/16	7 1/2	90

VALVE SIZE	A	B	C	J	P	Q	R	S	AA	AB	WEIGHT
30"	NOTE AA	21.50	36	12	28	1.250	38.750	2.125	4	1.250-7	1790
36"	NOTE AA	25.06	42.750	12	32	1.500	46	2.375	4	1.500-6	2515
42"	NOTE AA	28.88	49.500	12	36	1.500	53	2.625	4	1.500-6	4405

- NOTE 1: FLOW MAY BE IN EITHER DIRECTION
 NOTE 2: VALVE SHAFT WILL MEET OR EXCEED REQUIREMENTS OF SHAFT TABLE PER AWWA STANDARD C-504 FOR APPLICABLE CLASS.
 NOTE 3: REFERENCE AWWA C-111 (A.N.S.I. A21-11)
 NOTE 4: "N" = NUMBER OF TURNS TO CLOSE
 NOTE 5: "P" = NUMBER OF BOLTS ON EACH FLANGE
 NOTE 6: "Q" = DIAMETER OF BOLTS
 NOTE 7: OPERATED BY 2" AWWA OPERATING / WRENCH NUT
 NOTE 8: 2200 OPERATOR ON 30" & 36"--4350 OPERATOR ON 42"
 NOTE 9: MAXIMUM LENGTH OF TORQUE TUBE (15 FEET)--BONNET SUPPORTS SHOULD BE USED ON ALL BONNETS EXCEEDING 6 FEET CENTERLINE OF VALVE TO CENTERLINE OF OPERATOR. ALL BONNET SUPPORTS SHALL BE SUPPLIED BY CUSTOMER
 NOTE AA: "A" VARIES TO ENGINEER SPECIFICATIONS
 *NOTE AB: APPROXIMATE WEIGHT PER EACH FOOT OF EXTENDED BONNET 150lbs (30"-42")



KENNEDY VALVE
 Division of McWane, Inc.
 1021 EAST WATER STREET ELMIRA, NEW YORK 14901

DWN: TRIJ
 DATE: 8/12/11
 DWG. NO.
 BFE-15-14C

30" THRU 42" STYLE 1450
 CLASS 150 BUTTERFLY VALVE
 WITH EXTENDED BONNET
 BURIED OPERATOR
 FLANGED ENDS

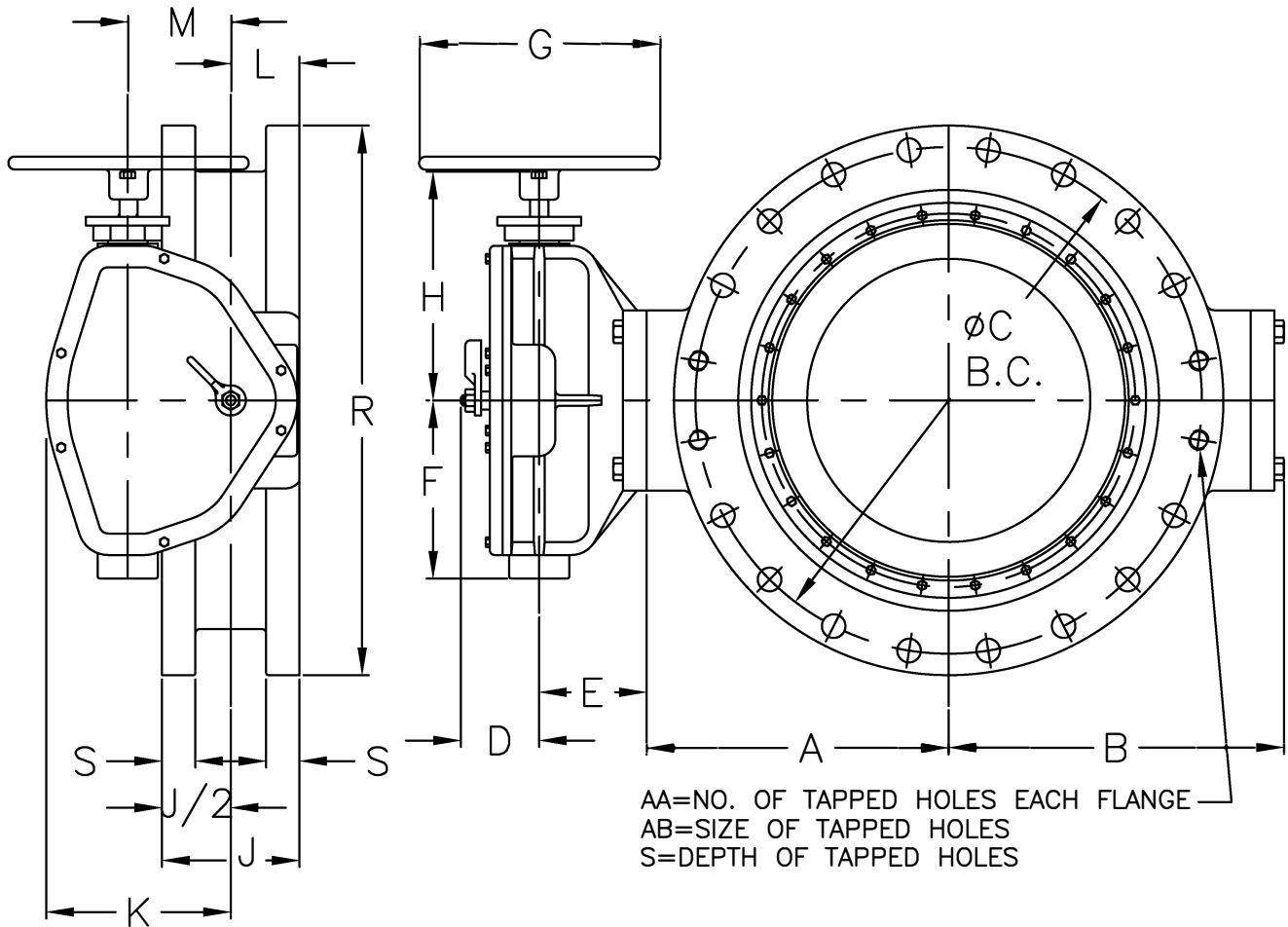

	OPERATOR MODEL	D	E	F	G	H	K	L	M	N
30" & 36"	2200	4 3/16	6 1/4	10 3/8	18	14 5/16	10 3/4	3 7/8	6	72
42"	4350	5 5/8	6 1/16	14 5/16	27	18	13 5/16	4 3/16	7 1/2	90

VALVE SIZE	A	B	C	J	P	Q	R	S	AA	AB	WEIGHT
30"	20.625	21.50	36	12	28	1.250	38.750	2.125	4	1.250-7	1790
36"	24.250	25.06	42.750	12	32	1.500	46	2.375	4	1.500-6	2515
42"	28.250	28.88	49.500	12	36	1.500	53	2.625	4	1.500-6	4405

NOTE 1: FLOW MAY BE IN EITHER DIRECTION

NOTE 2: VALVE SHAFT WILL MEET OR EXCEED REQUIREMENTS OF SHAFT TABLE PER AWWA STANDARD C-504 FOR APPLICABLE CLASS.

NOTE 3: REFERENCE AWWA C-504 FLANGES & DRILLING (A.N.S.I. 125)

NOTE 4: "N" = NUMBER OF TURNS TO CLOSE

NOTE 5: "P" = NUMBER OF BOLTS ON EACH FLANGE

NOTE 6: "Q" = DIAMETER OF BOLTS



KENNEDY VALVE

Division of McWane, Inc.
 1021 EAST WATER STREET ELMIRA, NEW YORK 14901

DWN: TRIJ
 DATE: 8/12/11
 DWG. NO.
 BFE-15-14D

30" THRU 42" STYLE 1450
 CLASS 150 BUTTERFLY VALVE
 POSITION INDICATOR
 HANDWHEEL OPERATOR
 FLANGED ENDS

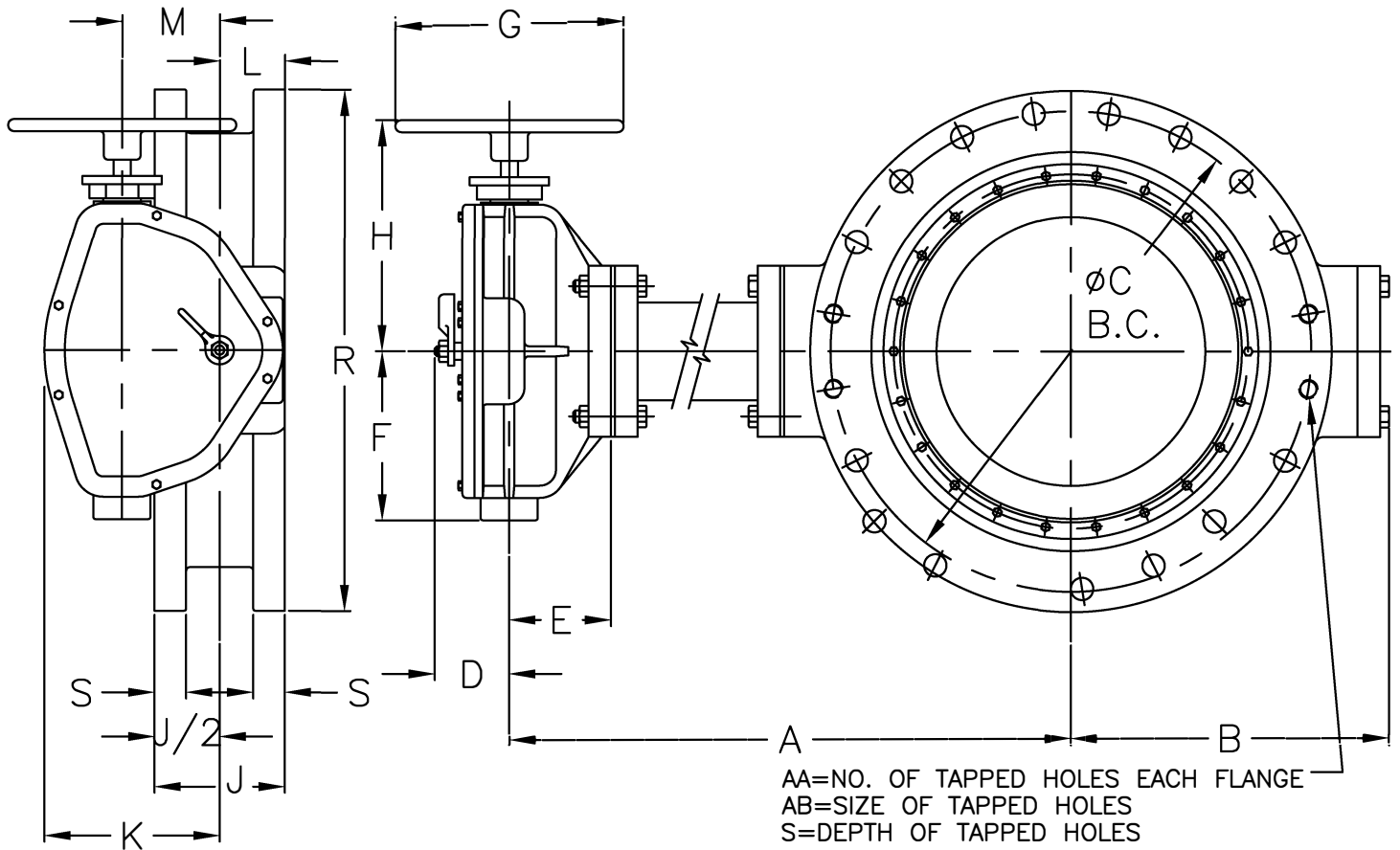

	OPERATOR MODEL	D	E	F	G	H	K	L	M	N
30" & 36"	2200	4 3/16	6 1/4	10 3/8	18	14 5/16	10 3/4	3 7/8	6	72
42"	4350	5 5/8	6 1/16	14 5/16	27	18	13 5/16	4 3/16	7 1/2	90

VALVE SIZE	A	B	C	J	P	Q	R	S	AA	AB	WEIGHT
30"	NOTE AA	21.50	36	12	28	1.250	38.750	2.125	4	1.250-7	1790
36"	NOTE AA	25.06	42.750	12	32	1.500	46	2.375	4	1.500-6	2515
42"	NOTE AA	28.88	49.500	12	36	1.500	53	2.625	4	1.500-6	4405

NOTE 1: FLOW MAY BE IN EITHER DIRECTION

NOTE 2: VALVE SHAFT WILL MEET OR EXCEED REQUIREMENTS OF SHAFT TABLE PER AWWA STANDARD C-504 FOR APPLICABLE CLASS.

NOTE 3: REFERENCE AWWA C-504 FLANGES & DRILLING (A.N.S.I. 125)

NOTE 4: "N" = NUMBER OF TURNS TO CLOSE

NOTE 5: "P" = NUMBER OF BOLTS ON EACH FLANGE

NOTE 6: "Q" = DIAMETER OF BOLTS

NOTE 7: MAXIMUM LENGTH OF TORQUE TUBE (15 FEET)--BONNET SUPPORTS SHOULD BE USED ON ALL BONNETS EXCEEDING 6 FEET CENTERLINE OF VALVE TO CENTERLINE OF OPERATOR. ALL BONNET SUPPORTS SHALL BE SUPPLIED BY CUSTOMER

NOTE AA: "A" VARIES TO ENGINEER SPECIFICATIONS

*NOTE AB: APPROXIMATE WEIGHT PER EACH FOOT OF EXTENDED BONNET 150LBS(30"-42")



KENNEDY VALVE

Division of McWane, Inc.
1021 EAST WATER STREET ELMIRA, NEW YORK 14901

DWN: TRIJ

DATE: 8/17/11

DWG. NO.
BFE-15-14E

30" THRU 42" STYLE 1450
CLASS 150 BUTTERFLY VALVE
WITH EXTENDED BONNET, POSITION
INDICATOR & HANDWHEEL OPERATOR
FLANGED ENDS

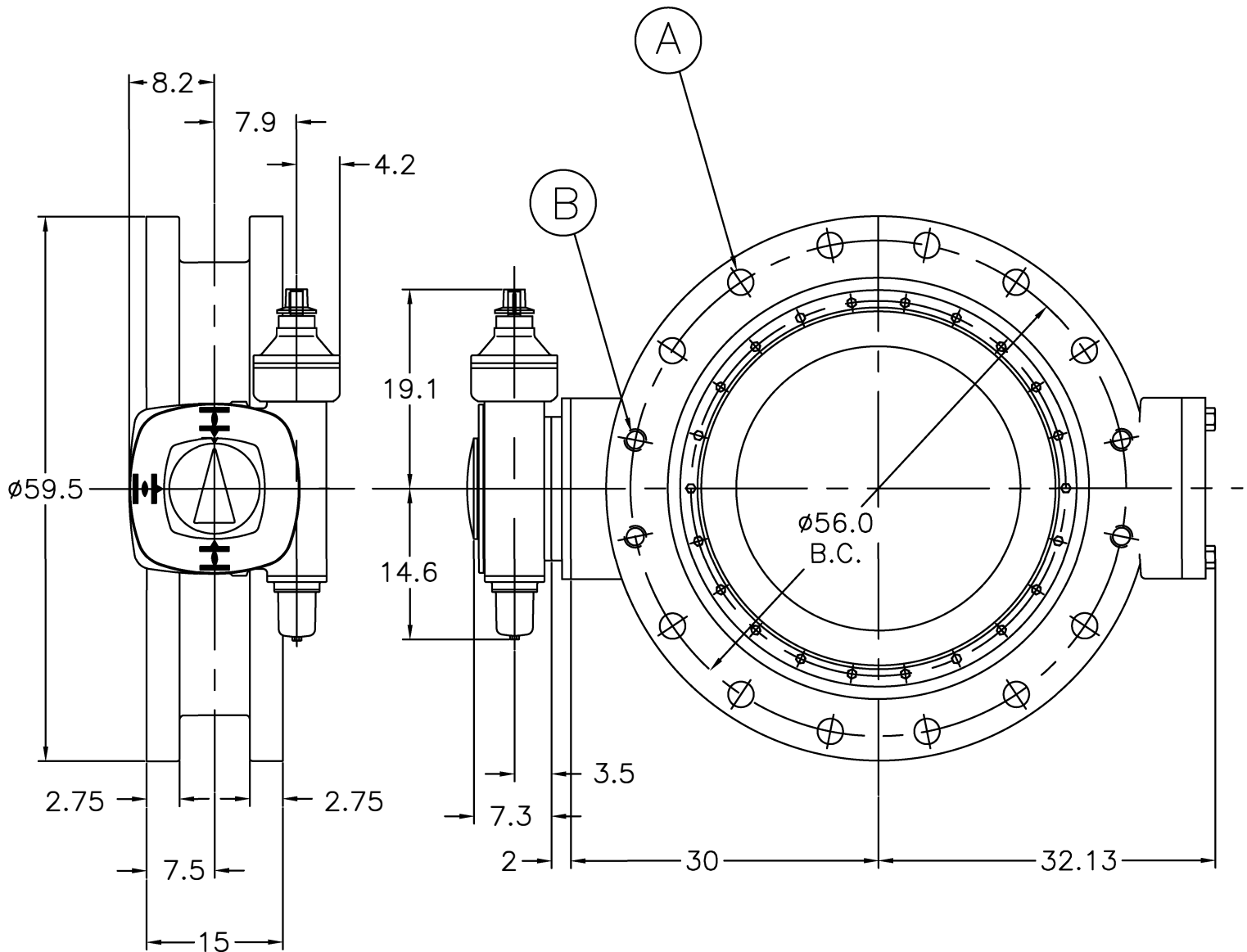

- NOTE 1: FLOW MAY BE IN EITHER DIRECTION
 NOTE 2: VALVE SHAFT WILL MEET OR EXCEED REQUIREMENTS OF SHAFT TABLE PER AWWA STANDARD C-504 FOR APPLICABLE CLASS.
 NOTE 3: REFERENCE AWWA C-504-B & DRILLING (A.N.S.I. 125)
 NOTE 4: NUMBER OF TURNS TO CLOSE = 108
 NOTE 5: OPERATED BY 2" AWWA OPERATING / WRENCH NUT
 NOTE 6: A = (44) ϕ 1.50" BOLTS PER FLANGE
 NOTE 7: B = (8) 1.50-6 UNC x 2.25 DEEP TAPPED HOLES EACH FLANGE
 NOTE 8: APPROXIMATE WEIGHT = 6300lbs.



KENNEDY VALVE
 Division of McWane, Inc.
 1021 EAST WATER STREET ELMIRA, NEW YORK 14901

DWN: TRIJ
 DATE: 8/25/11
 DWG. NO.
 BFE-15-48A

48" STYLE 1450
 CLASS 150 BUTTERFLY VALVE
 (AUMA GS200.3/GZ200.3:8 GEAR BOX)
 BURIED OPERATOR
 FE X FE ENDS

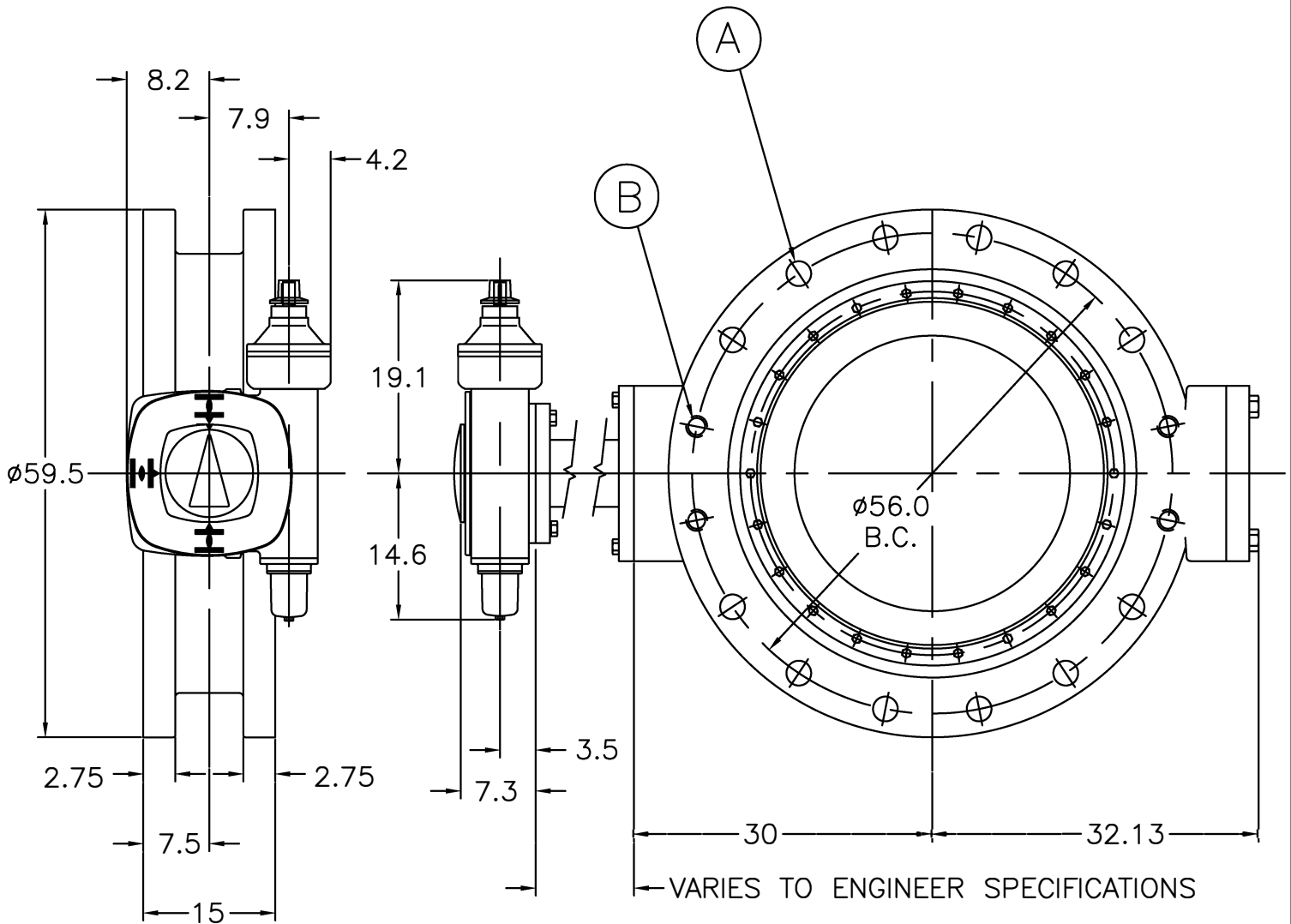

- NOTE 1: FLOW MAY BE IN EITHER DIRECTION
 NOTE 2: VALVE SHAFT WILL MEET OR EXCEED REQUIREMENTS OF SHAFT TABLE PER AWWA STANDARD C-504 FOR APPLICABLE CLASS.
 NOTE 3: REFERENCE AWWA C-504-B & DRILLING (A.N.S.I. 125)
 NOTE 4: NUMBER OF TURNS TO CLOSE = 108
 NOTE 5: OPERATED BY 2" AWWA OPERATING / WRENCH NUT
 NOTE 6: A = (44) ϕ 1.50" BOLTS PER FLANGE
 NOTE 7: B = (8) 1.50-6 UNC x 2.25 DEEP TAPPED HOLES EACH FLANGE
 NOTE 8: APPROXIMATE WEIGHT = 6300lbs.



KENNEDY VALVE

Division of McWane, Inc.
 1021 EAST WATER STREET ELMIRA, NEW YORK 14901

DWN:	TRIJ
DATE:	8/25/11
DWG. NO.	BFE-15-AA2

48" STYLE 1450
 CLASS 150 BUTTERFLY VALVE
 (AUMA GS200.3/GZ200.3:8 GEAR BOX)
 BURIED OPERATOR & EXTENDED BONNET
 FE X FE ENDS

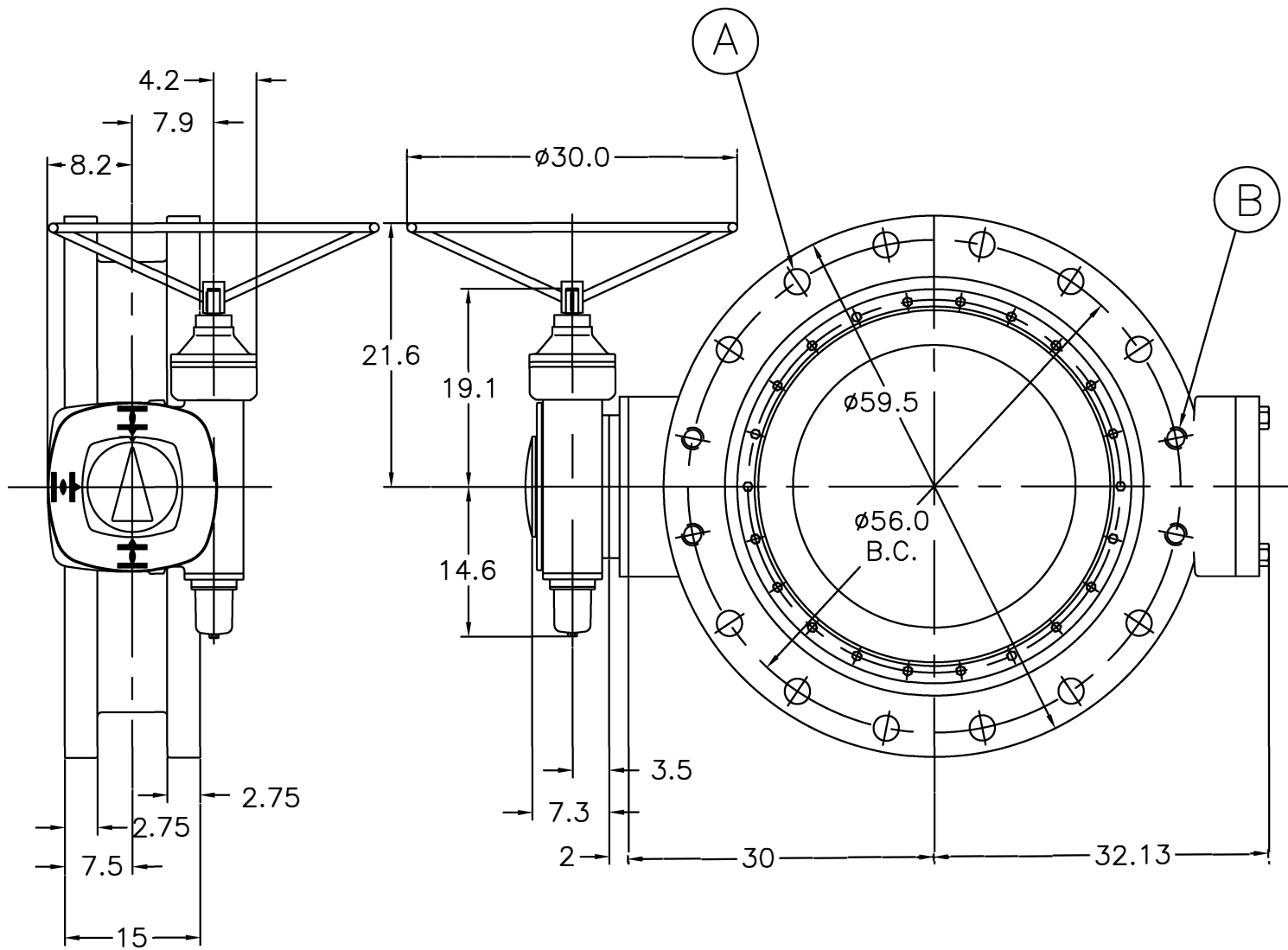

- NOTE 1: FLOW MAY BE IN EITHER DIRECTION
 NOTE 2: VALVE SHAFT WILL MEET OR EXCEED REQUIREMENTS OF SHAFT TABLE PER AWWA STANDARD C-504 FOR APPLICABLE CLASS.
 NOTE 3: REFERENCE AWWA C-504-B & DRILLING (A.N.S.I. 125)
 NOTE 4: NUMBER OF TURNS TO CLOSE = 108
 NOTE 5: MANUAL POSITION INDICATOR
 NOTE 6: A = (44) $\phi 1.50$ " BOLTS PER FLANGE
 NOTE 7: B = (8) 1.50-6 UNC x 2.25 DEEP TAPPED HOLES EACH FLANGE
 NOTE 8: APPROXIMATE WEIGHT = 6300lbs.



KENNEDY VALVE
 Division of McWane, Inc.
 1021 EAST WATER STREET ELMIRA, NEW YORK 14901

DWN: TRIJ
DATE: 9/19/11
DWG. NO. BFE-15-48B

48" STYLE 1450
 CLASS 150 BUTTERFLY VALVE
 (AUMA GS200.3/GZ200.3:8 GEAR BOX)
 HANDWHEEL OPERATOR
 FE X FE ENDS

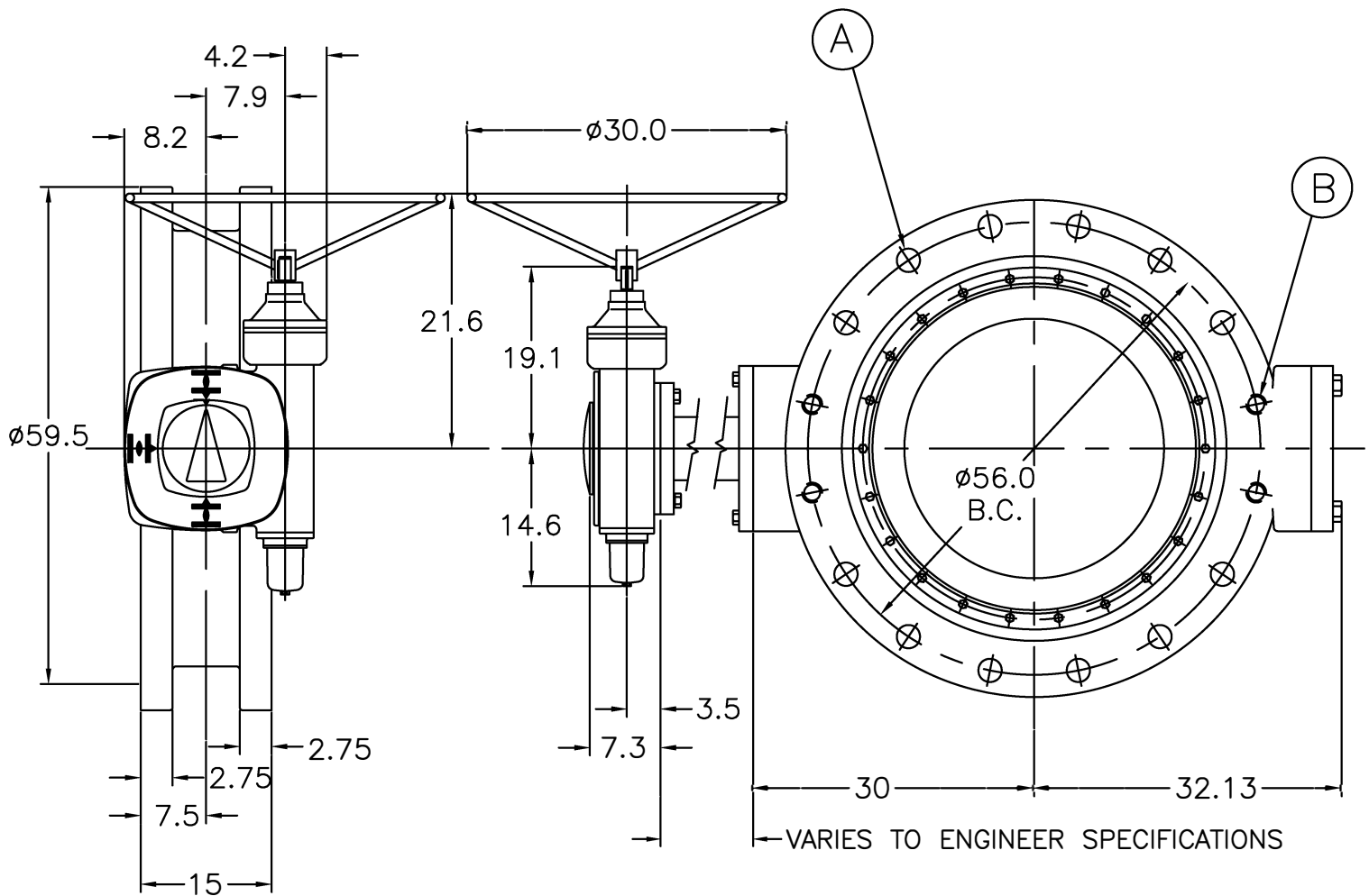

NOTE 1: FLOW MAY BE IN EITHER DIRECTION

NOTE 2: VALVE SHAFT WILL MEET OR EXCEED REQUIREMENTS OF SHAFT TABLE PER AWWA STANDARD C-504 FOR APPLICABLE CLASS.

NOTE 3: REFERENCE AWWA C-504-B & DRILLING (A.N.S.I. 125)

NOTE 4: NUMBER OF TURNS TO CLOSE = 108

NOTE 5: OPERATED BY HANDWHEEL

NOTE 6: A = (44) $\phi 1.50$ " BOLTS PER FLANGE

NOTE 7: B = (8) 1.50-6 UNC x 2.25 DEEP TAPPED HOLES EACH FLANGE

NOTE 8: APPROXIMATE WEIGHT = 6300lbs.



KENNEDY VALVE

Division of McWane, Inc.
1021 EAST WATER STREET ELMIRA, NEW YORK 14901

DWN:	TRIJ
DATE:	8/25/11
DWG. NO.	BFE-15-AA4

48" STYLE 1450
CLASS 150 BUTTERFLY VALVE
(AUMA GS200.3/GZ200.3:8 GEAR BOX)
HANDWHEEL OPERATOR &
EXTENDED BONNET - FE X FE ENDS

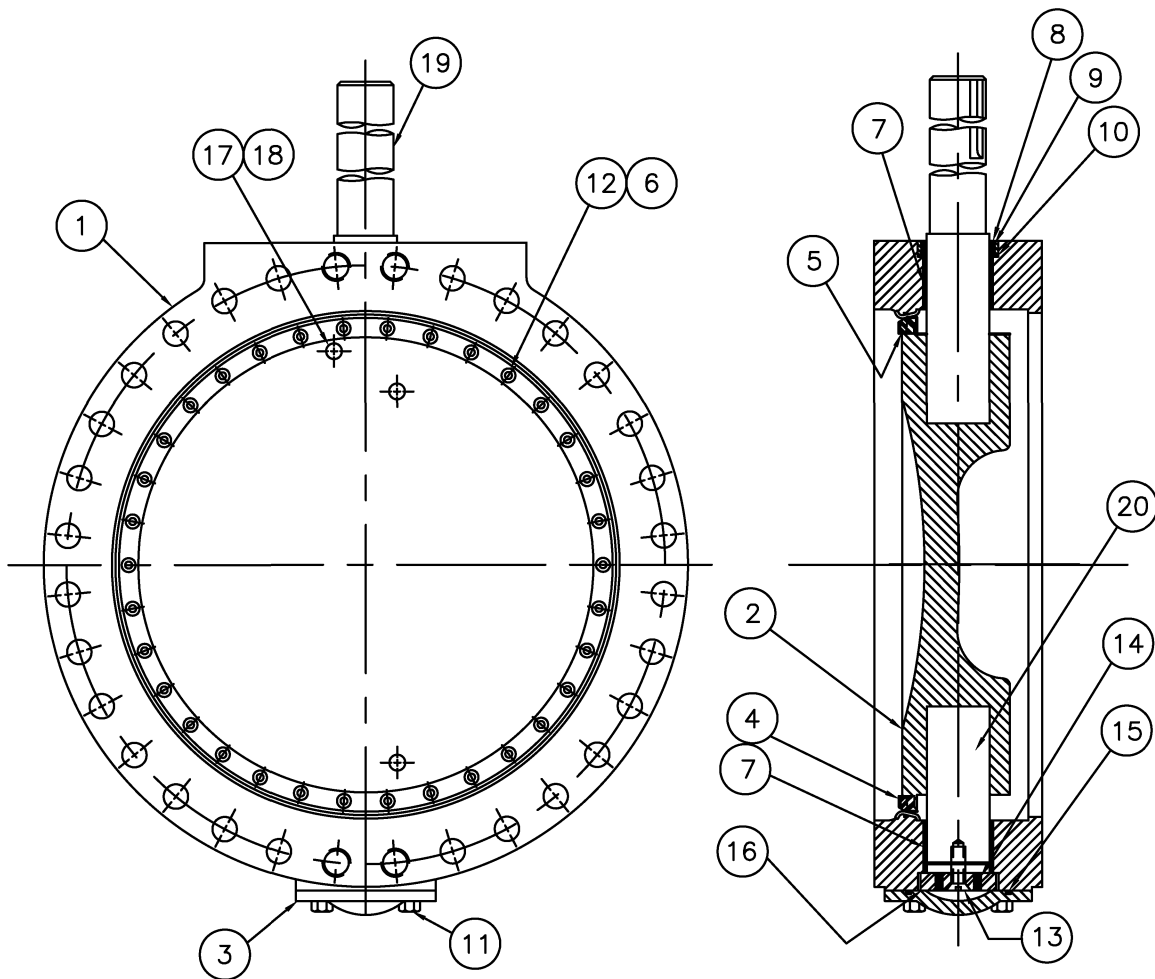

ITEM NO.	DESCRIPTION	MATERIAL
1	BODY, VALVE	DUCTILE IRON, ASTM A-536, GR. 70-50-05 W/304 STN. STL. SEAT
2	VANE	DUCTILE IRON, ASTM A-536, GR. 70-50-05
3	END COVER	FABRICATED A-36 STEEL
4	SEAT RING, VANE	EPDM
5	CLAMP RING, SEAT	304 STAINLESS STEEL
6	SEALING WASHER	NYLON
7	BUSHING, BODY	FIBERGLIDE
8	CARTRIDGE, SHAFT	BRONZE
9	SEAL, SHAFT	BUNA-N
10	SEAL, CARTRIDGE	BUNA-N
11	BOLT, END COVER	COMMERCIAL STEEL
12	SOCKET SCREW ~ FLAT HEAD	18-8 STAINLESS STEEL W/NYLOK INSERT
13	SOCKET SCREW ~ FLAT HEAD	18-8 STAINLESS STEEL W/NYLOK INSERT
14	SET SCREW ~ FLAT POINT	18-8 STAINLESS STEEL W/NYLOK INSERT
15	END COVER SEAL	BUNA-N
16	THRUST BEARING PLATE	BRONZE
17	TAPER PIN	416 STAINLESS STEEL
18	TAPER PIN BOLT	18-8 STAINLESS STEEL
19	SHAFT (OPERATOR)	304 STAINLESS STEEL
20	SHAFT (THRUST)	304 STAINLESS STEEL



KENNEDY VALVE

Division of McWane, Inc.
1021 EAST WATER STREET ELMIRA, NEW YORK 14901

DWN: TRIJ

DATE: 8/16/11

DWG. NO.
BFE-15-54A

54" STYLE 1450

CLASS 150 BUTTERFLY VALVE
SUB-ASSEMBLY / MATERIAL LIST
(NON-ADJUSTABLE PACKING)
FLANGED ENDS

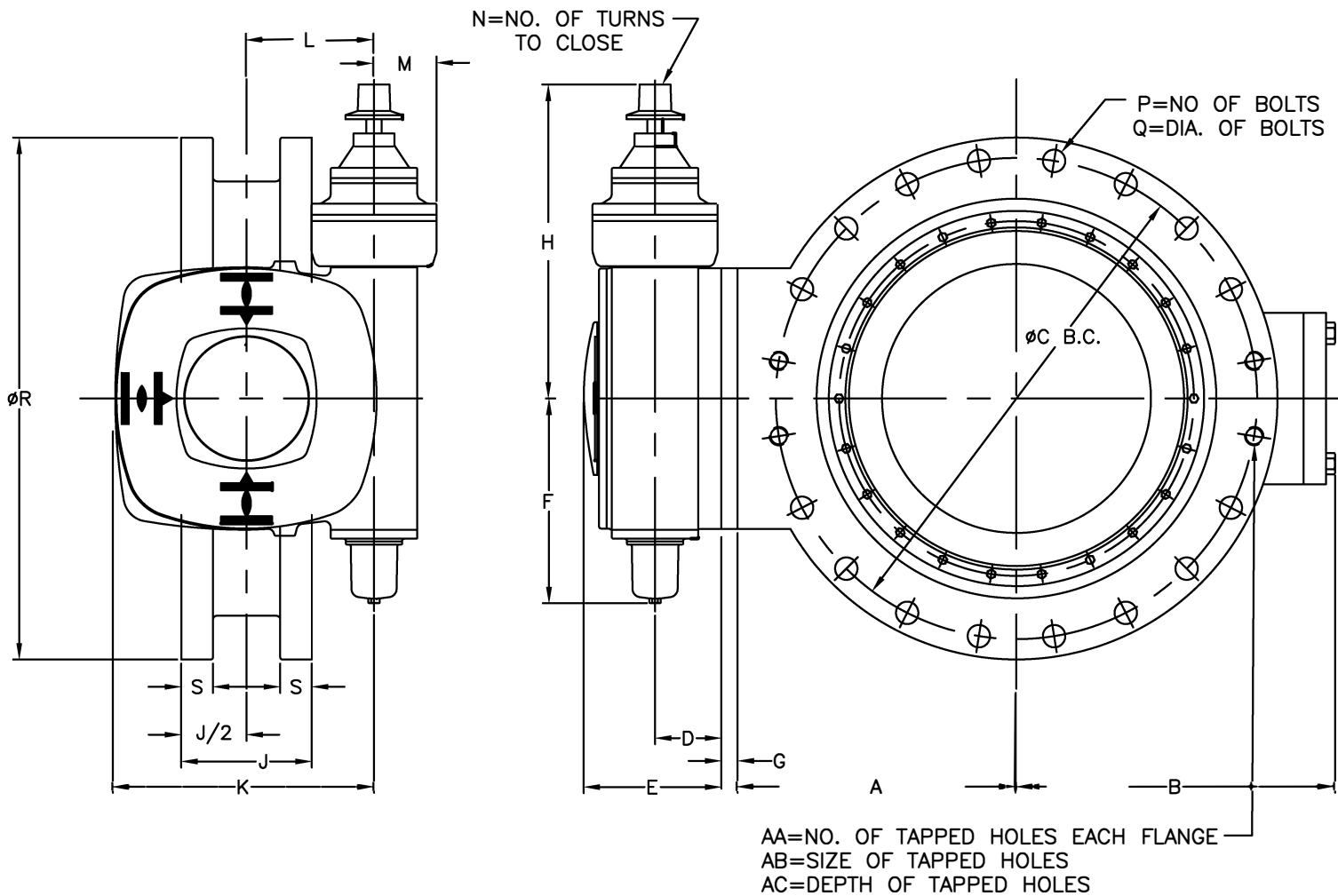

VALVE SIZE	A	B	C	G	J
54"	33.125	34.8	62.75	2.00	15.00

VALVE SIZE	P	Q	R	S	AA	AB	AC
54"	44	1.75	66.25	3	12	1 3/4-5	2.25

OPERATOR MODEL	D	E	F	H	K	L	M	N
GS 250.3/GZ250.3:8	5.1	9.2	15.8	22.0	19.8	9.8	4.8	103

- NOTE 1: FLOW MAY BE IN EITHER DIRECTION
 NOTE 2: VALVE SHAFT WILL MEET OR EXCEED REQUIREMENTS OF SHAFT TABLE PER AWWA STANDARD C-504 FOR APPLICABLE CLASS.
 NOTE 3: REFERENCE AWWA C-504 FLANGES & DRILLING (A.N.S.I. 125)
 NOTE 4: "N" = NUMBER OF TURNS TO CLOSE
 NOTE 5: "P" = NUMBER OF BOLTS ON EACH FLANGE
 NOTE 6: "Q" = DIAMETER OF BOLTS
 NOTE 7: OPERATED BY 2" AWWA OPERATING / WRENCH NUT



KENNEDY VALVE

Division of McWane, Inc.
1021 EAST WATER STREET ELMIRA, NEW YORK 14901

DWN: TRIJ
 DATE: 8/17/11
 DWG. NO.
 BFE-15-54B

54" STYLE 1450
 CLASS 150 BUTTERFLY VALVE
 BURIED OPERATOR
 (AUMA GS250.3/GZ250.3:8)
 FLANGED ENDS