

# C-10 CANAL GATE

C-10 gates offer reliable water control on canal and pipeline systems which operate at low and medium heads. They are built-to-last and designed for years of reliable service, offering a typical field life exceeding 40 years. These gates offer superior performance to “look alike” products and best-in-class construction available only from Waterman. Typical installations include: farm turnouts, control of industrial wastes, drainage and for tide control.

## KEY FEATURES

- Gray iron castings with minimum ¼” thickness.
- Superior rail material assures reliable performance and prevents deflection.
- Bolted steel frame in standard painted steel. Optional upgraded galvanized steel frame, or 304 stainless steel frame.
- Adjustable cast iron wedge blocks feature two machine bolts for dependable seating and water tightness.
- Machine-threaded stem provides ease of operation and extended life, choice of stem thread patterns.
- A solid rim “easy-grip” cast iron handwheel is standard.
- Heavy cast bronze lift nut.

## MOUNTING OPTIONS

**F** = Flatback for wall mounting (typically to a concrete headwall structure).

**S** = Spigot back for mounting to annular or recor spiral corrugated metal pipe.

**CIP** = Mounting to PVC plastic pipe with solvent welding (sizes up to 12”).

**C** = Mounting to concrete pipe (gate will be shipped with galvanized steel tapered setting collar).

**Type 4** = Mounting to plastic pipe with special two-part epoxy (sizes up to 18”).

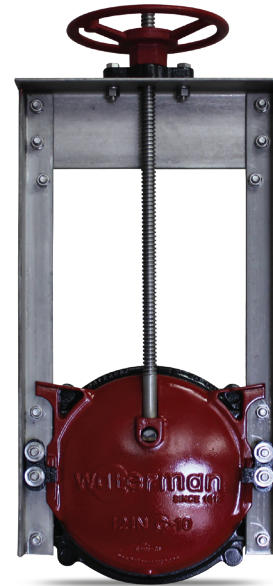

## OPTIONS

- Upgrade frame to galvanized steel.
- Upgrade frame to stainless steel, plus all stainless hardware.
- Upgrade finish to special epoxy, coal tar or total galvanized.
- Waterman Rising-Stem Extensions are factory installed to the height required, providing a rising stem and handwheel, keeping threads and lifts above the water level and allowing the amount of gate opening to be readily determined.
- Non-Rising Stem Extensions position the gate handwheel at convenient static operating elevations, eliminating hardware which might otherwise rise into traffic areas.

## SIZING

Sizes 6" – 24" maximum 23 feet of seating head

Sizes 30" – 36" maximum 11 feet of seating head

Sizes 42" – 48" maximum 9 feet of seating head

Sizes 54" and above maximum 6 feet of seating head

Not for use in unseating head applications in any circumstance. Use model C-20 instead.



**WATERMAN VALVE LLC**

25500 Road 204, Exeter, CA 93221 [www.WatermanUSA.com](http://www.WatermanUSA.com) 800.331.0808



# C-10 CANAL GATE

## C-10 CANAL GATE PARTS

C-10 Canal Gate Parts		
Number	Name	Quantity
1	Frame	1
2	Cover	1
3	Wedge (R&L)	2
4	Guide Rail (R&L)	2
5	Headrail	1
6	Stem	1
7	Handwheel	1
8	Thrust Collar	1
9	Lift Nut	1
10	Wedge Bolt	4
11	Wedge Nut	4
12	Frame Bolt	4
13	Frame Nut	4
14	Collar Bolt	2
15	Collar Nut	2
16	Stop Bolt & Nut	1
17	Limit Nut (optional)	1

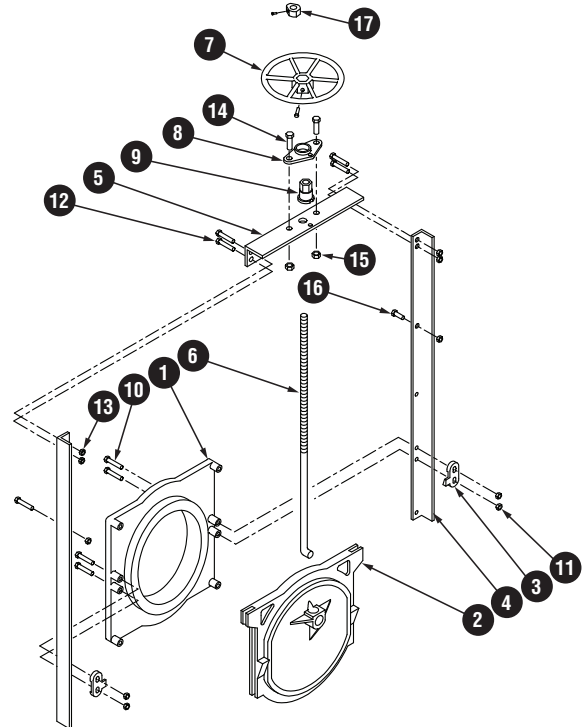

## CL-10 CANAL GATE – IMPROVED CLOG RESISTANCE IN PARTIAL OPEN MODE

Waterman CL-10 Canal Gates are identical to our model C-10 Gates with the exception of the cast iron cover (slide) which is of a flat plate type construction with ribs reinforcing its face, to withstand the maximum heads as noted for our C-10 gates. This gate cover also features a square bottom design, which allows a more open “clog-free” flow at points of initial opening. The seat being only slightly raised above the cover plate surface helps prevent trash from collecting behind the cover which can cause difficulty in operation. Available with threaded thrust nut for true NRS application. All parts are interchangeable with our Standard C-10 gate. Available in a variety of sizes, consult factory.

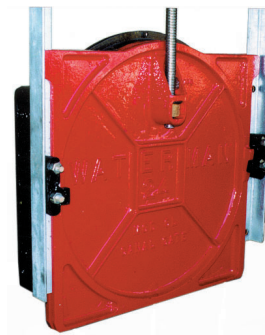

Shown with optional threaded thrust nut for true non-rising stem operation

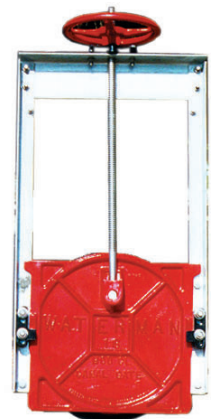

Flat plate type, square bottom



WATERMAN VALVE LLC

25500 Road 204, Exeter, CA 93221 www.WatermanUSA.com 800.331.0808



# C-10 CANAL GATE

## Materials of Construction

No.	Name	Material
1	Frame	Cast Iron ASTM A126 Class B
2	Cover	Cast Iron ASTM A126 Class B
3	Wedge (R&L)	Cast Iron ASTM A126 Class B
4	Guide Rail (R&L)	Structural Steel ASTM A-36
5	Headrail	Structural Steel ASTM A-36
6	Stem	Stainless Steel
7	Handwheel	Cast Iron ASTM A126 Class B
8	Thrust Collar	Cast Iron ASTM A126 Class B
9	Lift Nut	Machined Brass
10	Wedge Bolt	
11	Wedge Nut	
12	Frame Bolt	
13	Frame Nut	
14	Collar Bolt	
15	Collar Nut	
16	Stop Bolt & Nut	
17	Limit Nut (optional)	Machined Brass

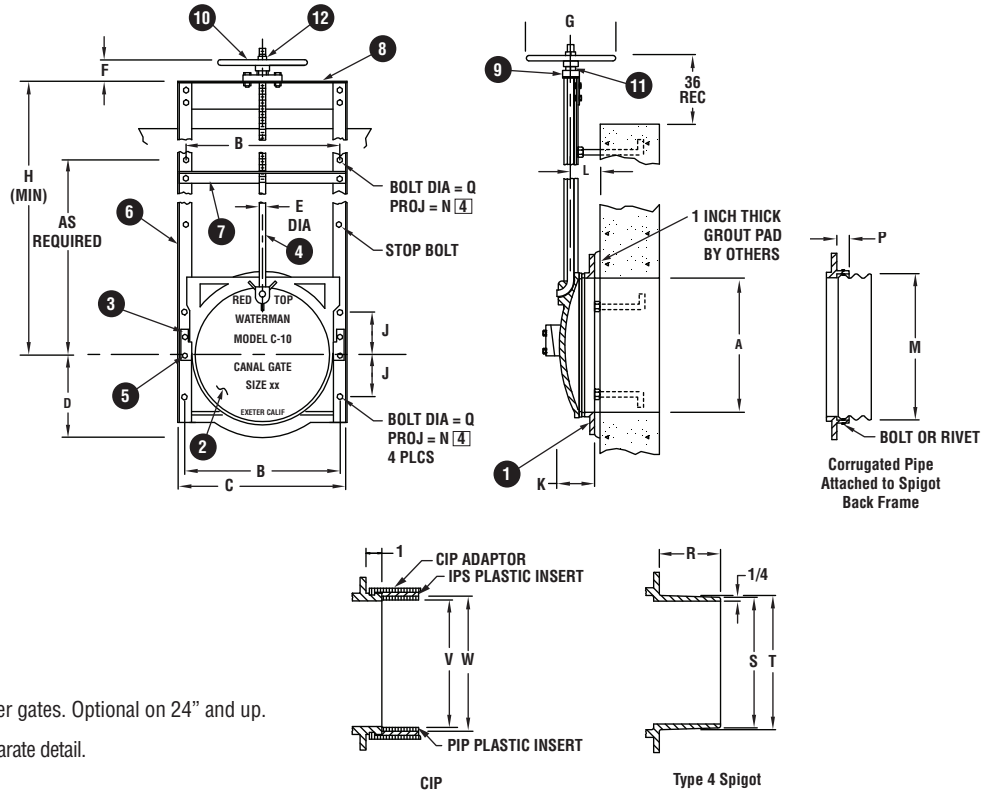

## NOTES

- 1 TYPE 2 lubricated ball bearing lift standard on 48" and larger gates. Optional on 24" and up.
- 2 Applies to spigotback gate only. Optional spigot, shown in separate detail.
- 3 All dimensions are also applicable for model CL-10.
- 4 Add grout pad thickness to anchor bolt projection.
- 5 Type 3R4 2:1 lift used, mounted to headrail.

## DIMENSIONS IN INCHES

A	B	C	D	E	F	G	H	J	K	L	M <sup>[2]</sup>	N	P <sup>[2]</sup>	Q	R	S	T	V	W
6	8	9 7/8	4	7/8	2 7/8	10	24	3	3.5	2 5/8	7	3.5	2.25	1/2				6.16	6.645
8	10	12	4 7/8	7/8	2 7/8	10	24	3	3.75	2.5	9	3.5	2.25	1/2	4	7 13/16	8	8.18	8.645
10	12	13 7/8	6	7/8	2 7/8	10	24	3.5	3.75	2.5	11	3.5	2.25	1/2	3 7/8	9 7/8	10	10.22	10.77
12	14	15 7/8	7	7/8	2 7/8	10	24	4	3.5	3	13	4	2.25	1/2	4	11 7/8	12	12.27	12.78
14	16	17 7/8	8	7/8	2 7/8	10	27	4.75	3.75	3.25	15	4	2.25	1/2					
15	17	18 7/8	8 7/8	7/8	2 7/8	10	30	5	4.5	3.5	16	4	2 1/8	1/2	4	14 7/8	15		
16	18.75	20 5/8	9 7/8	7/8	2 7/8	10	32	5.5	4.5	3.5	17	4.5	2.25	5/8					
18	21	22 7/8	10.5	1	3 1/8	12	34	6	4.5	4.25	19	4.5	2.25	5/8	4	17 13/16	18		
20	23.25	25 1/8	11.75	1	3 1/8	12	38	7	4.75	4	21	4.5	2.25	5/8					
21	24	25 7/8	12 5/16	1	3 1/8	12	40	7	4.75	4	22	4.5	2.25	5/8					
24	27.25	29 1/8	13 7/8	1	3 1/8	12	44	8	5.75	4 1/8	25	4.5	2.25	5/8					
30	33.75	36 1/8	17 3/8	1 1/8	4	15	54	10	6	4.5	31	6	2.25	3/4					
36	39.75	42 1/8	20.5	1 1/8	4	15	62	12	6.25	5 3/8	37	6	2 1/8	3/4					
42	45.75	48 3/8	23 5/8	1.5	5	18	84	14	7	6	43	6	2.5	3/4					
48	51.75	54 3/8	26.75	1.5	6	24 <sup>[1]</sup>	90	16	7 3/8	6 1/8	49 1/8	6	2.5	3/4					
54	58.5	61.5	30	2	6	30 <sup>[1]</sup>	100	18	7 7/8	6.5	55 1/8	7	3	1					
60	65	68	34	2	6	30 <sup>[1]</sup>	102	20	8 1/8	7 1/8	61 1/8	8	3.25	1					
72	77.5	80.25	41	2	13	5 <sup>[5]</sup>	121	25.5	10 5/8	8.75	73.25	8	3 3/8	1					