



HEAVY DUTY CAST IRON SLUICE/SLIDE GATES

Compliant with AWWA C560

**Best-in-Class Construction for
Long Life in Critical Applications**

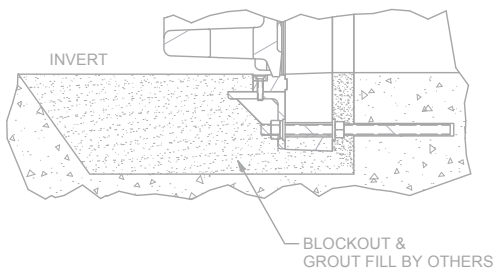
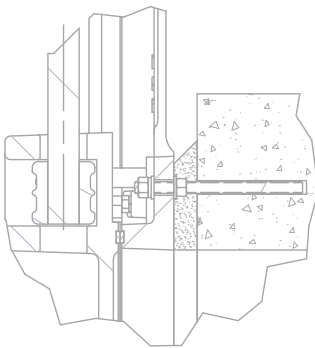
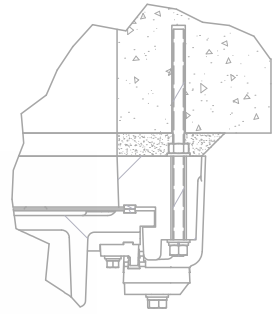

TABLE OF CONTENTS

Product Summary.....	3
Self Contained vs. Non-Self Contained.....	4
Q-Seal Flushbottom Seal (Full Flow Opening).....	5
Resilient Seated (Gliding Seal) Option.....	5
Wedges.....	6
Thimble Mounting.....	6
How to Specify.....	7
Gate Dimensions and Specs. 6"-14" width.....	8
Gate Dimensions and Specs. 15"-20" width.....	9
Gate Dimensions and Specs. 21"-27" width.....	10
Gate Dimensions and Specs. 30"-35" width.....	11
Gate Dimensions and Specs. 36"-39" (and 1000 mm) width.....	12
Gate Dimensions and Specs. 42" width.....	13
Gate Dimensions and Specs. 48" width.....	14
Gate Dimensions and Specs. 54"-60" width.....	15
Gate Dimensions and Specs. 66"-78" (and 2000 mm) width.....	16
Gate Dimensions and Specs. 84"-96" width.....	17
Gate Dimensions and Specs. 102"-144" width.....	18
Typical Specifications.....	19-24

For the latest digital copies of all Waterman specifications and drawings,
visit our website at www.WatermanUSA.com

CAST IRON SLUICE / SLIDE GATES

Waterman Cast Sluice Gates are used in applications where safety and reliable performance are essential (dams, tidal environments, water treatment plants) and where outstanding product longevity is desired. Waterman cast gates are preferred for high-head (up to 200') and high debris environments as well as for critical gateways in treatment plants.

Key Features:

- **Thick, highly rigid frame and cover** to handle high heads and environments with floating debris. Cover and frame design fully tested to meet or exceed design specifications with finite element analysis. Stress, deflection, and vibration are measured based on both seating and unseating heads and other external loading. Analysis allows gate to perform with maximum reliability and minimum leakage.
- **Proven design** as one of the industry's oldest manufacturers of cast iron sluice gates, Waterman has thousands in operation worldwide.
- **Low leakage machined metallic seating surfaces** create a reliable tight seal, minimizing leakage. Seating faces are corrosion-resistant and are mechanically locked into the gate frame and cover in full-width dovetail grooves. Seats are made of a malleable material that is formed into the grooves without need for fasteners. The fullwidth dovetail design prevents the possibility of leakage between the seat material and the castings.
- **High performance adjustable wedge system** offers easier maintenance and proven performance. Assures proper reliable closure of top, bottom and sides. (Bottom wedges not required with Q-Seal Flushbottom Seal)
- **Choice of cast iron, ductile iron, 2% Ni and Ni-Resist cast iron alloys**
- **Design flexibility with the industry's largest selection of sizes and mounting options:** gate shapes available in square and rectangular, with square, rectangular or round openings to meet the needs of even the most unusual applications.
- **Offered for a full range of mounting options:** gates offered for submerged service, wall mounting, downward opening (decanting), flange mount and more.

Gate Designs Available:

Most gate sizes are available as **self-contained gates** where the operating device is mounted on the top yoke of the gate. Operating loads are carried by the gate frame. The thrust required to open the gate is transmitted by the yoke and guides to the gate frame, unlike non-self-contained gates where these loads are carried by the structure above the gate where the floor stand is mounted. The self-contained design is used where the space above the gate is minimal and/or where structural supports limit the option of using a separate floor stand.

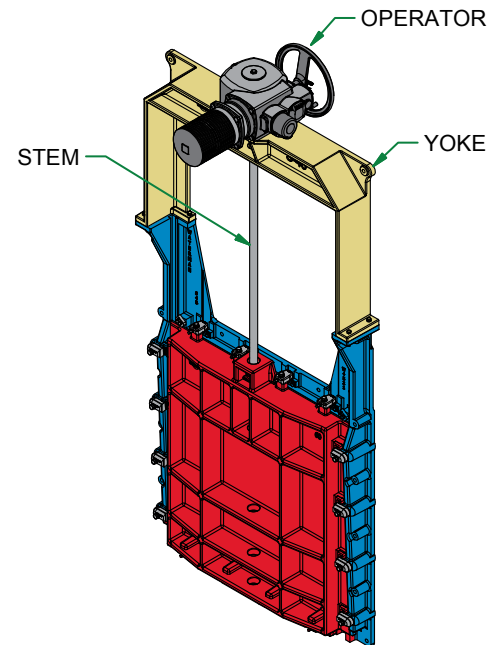

Non-self-contained gates separate the frame and guides from the operating floor stand. Often a crank-operated floor stand with a geared head is used to support the opening and closing thrust loads. These gates can also be fitted with motor and hydraulic actuators. Stem lengths can be varied to the application and are supported as needed by adjustable stem guides.

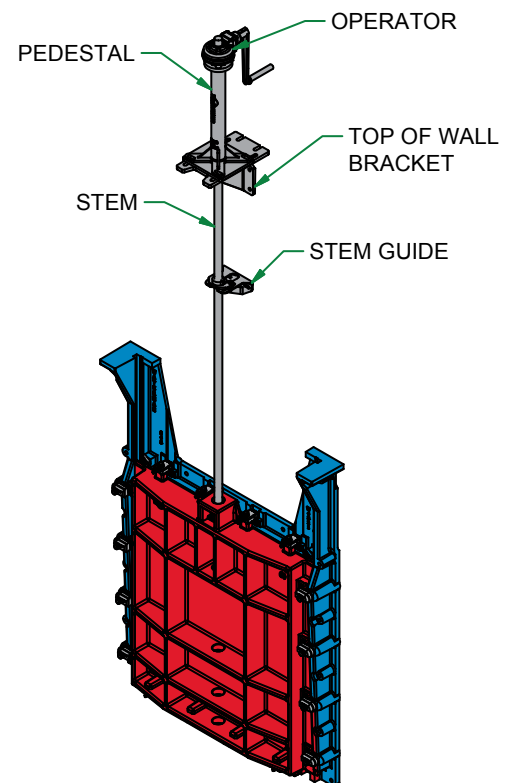

Special Options:

Q-Seal™ Flushbottom Seal is available for applications where a full, continuous opening area without obstructions to impede solids is desirable. Typical applications include wastewater settling tanks, aeration tanks, sedimentation and flocculation basins.

The flushbottom closure features a continuous neoprene seal contained in the invert of the frame, providing a flat plane across the bottom of the gate without projections into the opening. The seal is firmly supported on three sides, exposing only the flat top side, minimizing the chance for damage. When a flushbottom seal is used, a smooth rounded projection is used on the bottom of the slide. When this compresses against the flushbottom Q-Seal, it makes a watertight closure.

Why Choose Q-Seal™ Option:

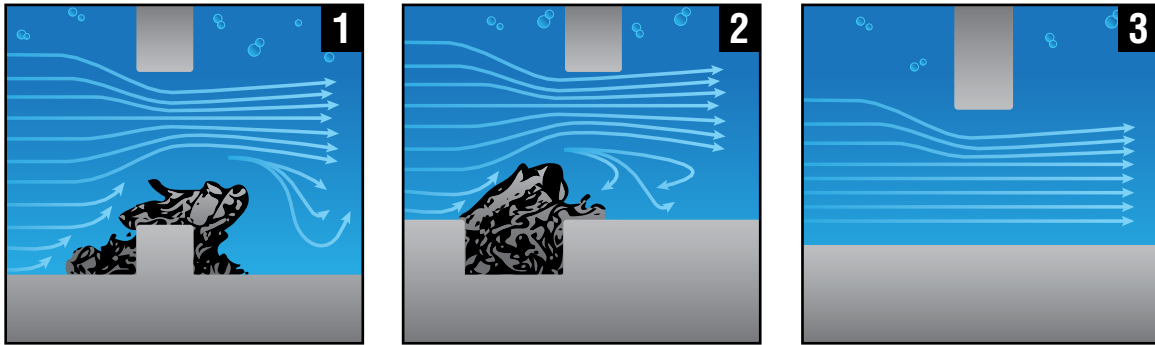

1. Raised seat wall traps debris 2. Recessed pocket seat traps debris 3. Q-Seal creates flow-through opening, no debris

Resilient Seated (Gliding Seal) Gates

High Performance Resilient Gliding Seal Gates are used in applications where extremely low leakage is required. The key difference from a traditional cast iron gate is in the seating materials (PVC and rubber seating surfaces instead of bronze) and tapered wedging action of the gate frame and seat. Waterman Resilient Gliding Seal Gates offer a very low leakage rate equal to 1% of the AWWA C560 specified maximum allowable leakage (The net allowable leakage rate on a Resilient Seated Waterman Gate is 0.001 GPM per foot of perimeter). Waterman resilient seated cast gates are preferred for applications with seating or unseating heads up to 25 feet. Each gate is custom built to your requirements.

The Waterman Adjustable Wedge System

High-performance wedges are used to insure tight contact between the bronze seating surfaces of the cover and the frame. As the gate moves, the wedges pull the top and bottom seats into contact.

Wedges are cast bronze and are precision machined and are designed for maximum adjustability and serviceability.

The **side wedge system** is the most critical portion of the design. It is designed to resist the vertical loads from gate operation and is designed to carry much of the unseating head load. The loads in the side wedge system can be high, so the right design is critical.

Waterman's B and B-1 wedge systems place the adjustable portion of the side wedge on the slide and keys it in place, preventing twisting or rotation. The corrosion resistant fasteners allow for long life and also for field-replacement of damaged wedges. The performance of the wedge system is modeled with finite element analysis to assure an even load distribution.

Top and bottom wedges (where applicable) are fully-adjustable units that are easily set and locked into place with corrosion-resistant fasteners. They use a bronze hook-and-loop design and are also keyed in place to prevent movement under force.

Wall Thimble Mounting – The Preferred Method

A wall thimble is a heavy cast iron fitting positioned into the wall structure. It has a machined flat front face which is pre-drilled and tapped to accurately mount the gate. Using a thimble pre-positions and aligns the gate to the opening and protects the gate against distortion. It also allows the gate to be removed for cleaning, painting or service. Use of a thimble increases costs slightly, but eliminates issues and errors that sometimes occur with other mounting methods.

Thimble Types:

- **Type “F”** – most commonly used with seating pressure and moderate unseating pressure. Has a flange for mounting on the gate-side only. The small inner staff provides a cleat to hold the thimble securely in the wall.
- **Type “E”** – has flanges on both the inlet and outlet side of the wall. Used with higher unseating pressure, high debris and high hazard applications. These are typically drilled on the rear flange for mating to a pipe.
- **Type “MJ”** – has a mechanical joint flange on one side for connection to pipeline or penstock. It includes a minor bolt flange for cinching a following ring against a ring rubber gasket.
- **Type “Bell”** – similar to the mechanical joint, but with a bell-end to accept a pipe. Caulking of the bell is required to provide a seal. Adaptations are available for concrete, plastic and steel pipe.

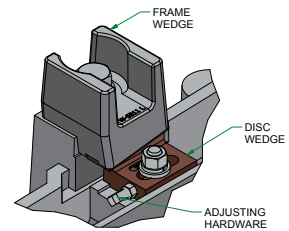

SIDE WEDGE SYSTEM

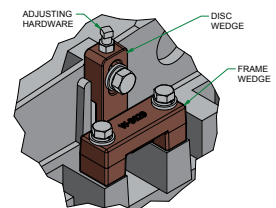
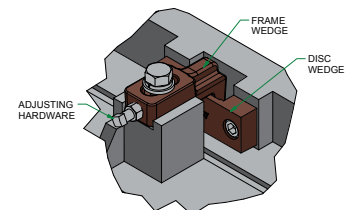

TOP AND BOTTOM WEDGE SYSTEM

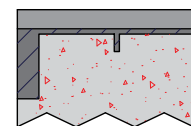

F TYPE THIMBLE

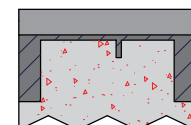

E TYPE THIMBLE

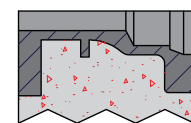

M-J TYPE THIMBLE

HOW TO SPECIFY WATERMAN AWWA CAST IRON SLUICE / SLIDE GATES

To make it convenient for you to size and specify a Waterman Cast Iron Sluice / Slide Gate, we have provided charts of the standard available sizes and design head ratings available.

Multiple design head options are presented for different sizes to allow selection of the most effective and economical solution for your project.

If you have an application for a gate that is not met by the available sizes listed here, please contact us for additional information and practical solutions.

GENERAL SELECTION AND SPECIFICATION

Size:

- The size of the gate (width and height) and the head rating (design and operating) are used to specify the gate required.

Design and Operating Head:

- The design head shown in the tables is the maximum head that the gate has been engineered to withstand. Waterman's engineers use tools such as Finite Element Analysis to verify the design.
- The operating head is the head under which the gate is to be opened and closed. The operating head is used to size the hoist mechanism and the stem requirement.
- Include both design and operating head in your specifications.

Installation Clearance:

- The minimum installation clearance on sides and bottom shall be at least 1".

Notes:

- Dimensions provided are for selection and are based on standard Waterman drawings. Waterman will furnish gates only for applications where the head is equal to or less than the design and operating heads indicated.



CAST GATE SIZES 6"-14"

SIZE	DESIGN HEAD FT. (M)		DIMENSIONS							
	SEAT	UNSEAT	A	B	C	D	E	F	G ± 1/4"	H ± 1/4"
6 x 6 (150 x 150)	276.8 (84)	81.6 (25)	11-1/8 (283)	6 (152)	7-1/2 (191)	13-1/8 (333)	13-5/8 (346)	4-3/4 (121)	2-1/4 (57)	4-3/4 (121)
6 x 6 (150 x 150)	600 (183)	60 (18)	15-3/4 (400)	6-1/2 (165)	10 (254)	15-5/16 (389)	17-1/4 (438)	6-3/4 (171)	4-1/16 (103)	7-1/2 (191)
6 x 6 (150 x 150)	618 (188)	233 (71)	15-1/2 (394)	6-1/2 (165)	9-13/16 (249)	14-3/4 (375)	16 (406)	8-1/2 (216)	4-1/2 (114)	7-1/2 (191)
8 x 8 (200 x 200)	151 (46)	67 (20)	18 (457)	8 (203)	10-3/16 (259)	15 (381)	21-1/2 (546)	8-1/2 (216)	4-1/2 (114)	7-1/2 (191)
8 x 8 (200 x 200)	240.0 (73)	86.5 (26)	13-1/8 (333)	7 (178)	9-1/2 (241)	16-1/8 (410)	16-5/8 (422)	4-3/4 (121)	2-1/4 (57)	4-3/4 (121)
8 x 8 (200 x 200)	575 (175)	210 (64)	18 (457)	8-1/2 (216)	10-9/16 (268)	18-1/4 (464)	20-7/16 (519)	6-13/16 (173)	4-1/8 (105)	7-1/2 (191)
10 x 10 (250 x 250)	173.8 (53)	66.5 (20)	15-1/8 (384)	8 (203)	11-1/2 (292)	19-1/8 (486)	19-5/8 (498)	4-3/4 (121)	2-1/4 (57)	4-3/4 (121)
10 x 10 (250 x 250)	475 (145)	45 (14)	20 (508)	9-1/2 (241)	12-1/2 (318)	21-1/4 (540)	23-3/8 (594)	6-13/16 (173)	4-3/16 (106)	8-1/2 (216)
10 x 10 (250 x 250)	586 (179)	99 (30)	20 (508)	9-1/2 (241)	12-1/8 (308)	18-1/8 (460)	24-1/2 (622)	9-1/2 (216)	5 (127)	8-1/2 (216)
12 x 12 (305 x 305)	139.0 (42)	40.3 (12)	17-1/2 (445)	9-1/4 (235)	13-1/2 (343)	22-18 (562)	22-15/16 (583)	5-7/8 (149)	3-1/4 (83)	5-7/8 (149)
12 x 12 (305 x 305)	450 (137)	50 (15)	22-1/4 (565)	10-1/2 (267)	14-1/2 (368)	24-5/8 (625)	29-1/8 (740)	7-1/16 (179)	4-9/16 (116)	8-1/2 (216)
12 x 12 (305 x 305)	456 (139)	144 (44)	22-1/4 (565)	10-1/2 (267)	14-1/4 (362)	21-1/4 (540)	27-3/8 (695)	9-1/2 (241)	5 (127)	8-1/2 (216)
12 x 18 (305 x 460)	155 (47)	50 (15)	22 (559)	13-1/2 (343)	20-3/4 (527)	30-3/8 (772)	36-3/8* (924*)	8-3/4 (222)	5-1/2 (140)	8-3/4 (222)
12 x 24 (305 x 610)	150 (46)	55 (17)	23-1/2 (597)	16-1/2 (419)	28-5/8 (727)	39 (991)	44 (1118)	11-1/2 (292)	7 (178)	11 (279)
14 x 14 (360 x 360)	149 (45)	35 (11)	24 (610)	11-1/2 (292)	16-1/8 (410)	24-1/4 (616)	30 (762)	9-1/2 (241)	5 (127)	8-1/2 (216)
14 x 14 (360 x 360)	255 (78)	43 (13)	24 (610)	11-1/2 (292)	16-5/8 (422)	27-13/16 (706)	31-11/16 (805)	7-3/4 (197)	4-11/16 (119)	8-1/2 (216)

NOTES:

* To top of fabricated yoke.

Seating and Unseating values are based on standard casting material, either Cast Iron ASTM A-126 CL. B or Ductile Iron, depending on model. Consult factory for details.

Additional material options available on request:
Class C Cast Iron, 2% Ni and Ni-Resist.

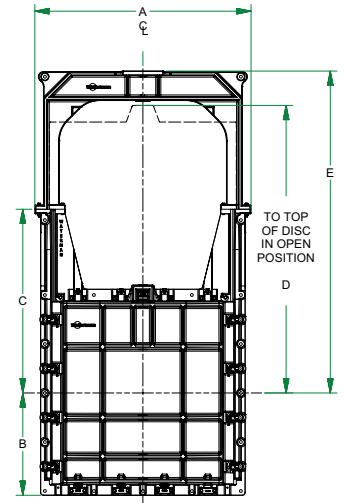

SELF CONTAINED

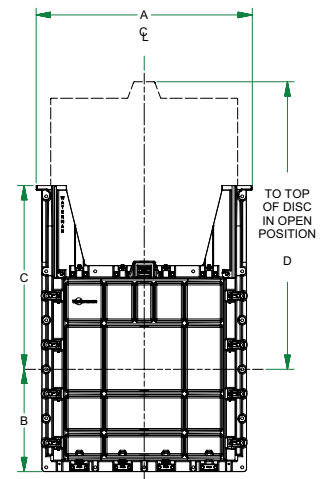

NON-SELF CONTAINED

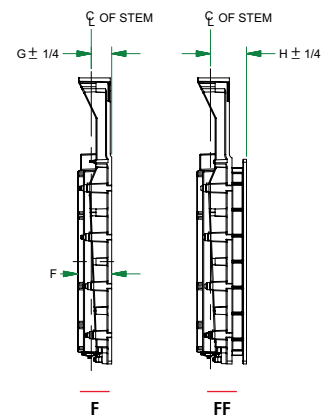

CAST GATE SIZES 15"-20"

SIZE	DESIGN HEAD FT. (M)		DIMENSIONS							
	SEAT	UNSEAT	A	B	C	D	E	F	G ± 1/4"	H ± 1/4"
15 x 15 (380 x 380)	114 (35)	39 (12)	25-1/2 (648)	11-1/2 (292)	17 (432)	25-1/4 (641)	31-3/4 (806)	9-1/2 (241)	5 (127)	8-1/2 (216)
15 x 15 (380 x 380)	250 (76)	42 (13)	25 (635)	12 (305)	17-1/2 (445)	29-5/16 (745)	33-1/8 (841)	7-3/4 (197)	4-11/16 (119)	8-1/2 (216)
15 x 15 (380 x 380)	276.7 (84)	72.1 (22)	24 (610)	12 (305)	17 (432)	28-7/8 (733)	30-3/16 (767)	8-1/4 (210)	4-3/4 (121)	8-1/8 (206)
16 x 16 (410 x 410)	63 (19)	24 (7)	26-1/4 (667)	12-1/2 (318)	18 (457)	27-1/16 (687)	33-1/2 (851)	9-1/2 (241)	5 (127)	8-1/2 (216)
16 x 16 (410 x 410)	92.9 (28)	45.5 (14)	25 (635)	12-1/2 (318)	18-3/16 (462)	30-3/8 (772)	31-11/16 (805)	8-1/4 (210)	4-3/4 (121)	8-1/8 (206)
16 x 16 (410 x 410)	245 (75)	41 (12)	26 (660)	12-1/2 (318)	19 (483)	30-7/8 (784)	35 (889)	7-3/4 (197)	4-11/16 (119)	8-1/2 (216)
16 x 16 (410 x 410)	319 (97)	114 (35)	26-1/4 (667)	12-1/2 (318)	18 (457)	31 (787)	33-1/2 (851)	9-1/2 (241)	5 (127)	8-1/2 (216)
18 x 12 (460 x 305)	260 (79)	96 (29)	28-5/8 (727)	10 (254)	20-1/2 (521)	21-1/4 (540)	27-1/4* (692*)	9-1/4 (235)	4-3/4 (121)	8-1/2 (216)
18 x 18 (460 x 460)	81.4 (25)	35.4 (11)	27 (686)	13-1/2 (343)	20 (508)	33-3/8 (848)	34-11/16 (881)	8-1/4 (210)	4-3/4 (121)	8-1/2 (216)
18 x 18 (460 x 460)	198 (60)	48 (15)	28 (711)	13-1/2 (343)	21 (533)	33-3/4 (857)	37-3/4 (959)	7-3/4 (197)	4-11/16 (119)	10 (254)
18 x 18 (460 x 460)	263 (80)	85 (26)	29 (737)	13-1/2 (343)	20-3/4 (527)	30 (762)	37 (940)	11-1/2 (292)	6-1/4 (159)	10 (254)
18 x 18 (460 x 460)	302 (92)	115 (35)	29 (737)	13-1/2 (343)	20-3/4 (527)	34 (864)	37 (940)	11-1/2 (292)	6-1/2 (165)	10-3/4 (273)
18 x 24 (460 x 610)	221 (67)	62 (19)	28-3/4 (730)	16-3/4 (425)	26-1/2 (673)	39-1/4 (997)	45-1/4* (1149*)	11-1/2 (292)	7 (178)	11 (279)
18 x 30 (460 x 760)	396 (121)	103 (31)	29 (737)	19-3/4 (502)	37-1/2 (953)	48-1/4 (1226)	55 (1397)	12-1/2 (318)	7 (178)	11 (279)
18 x 36 (460 x 910)	308 (94)	95 (29)	29 (737)	22-1/2 (572)	38 (965)	58-1/4 (1480)	63-5/8 (1616)	12-1/2 (318)	7 (178)	11 (279)
20 x 20 (510 x 510)	141.9 (43)	26.7 (8)	29 (737)	14-1/2 (368)	22 (559)	36-3/8 (924)	38-1/16 (967)	8-1/4 (210)	4-3/4 (121)	8-1/8 (206)
20 x 20 (510 x 510)	150 (46)	45 (14)	30 (762)	14-1/2 (368)	24-1/16 (611)	36-3/4 (933)	41-1/8 (1045)	8-1/8 (206)	5 (127)	10-1/2 (267)
20 x 20 (510 x 510)	235 (72)	67 (20)	31-1/2 (800)	15 (381)	23-3/4 (603)	33-3/4 (857)	41-1/2 (1054)	11-1/2 (292)	6-3/8 (162)	10-1/2 (267)

NOTES:

* To top of fabricated yoke.

Seating and Unseating values are based on standard casting material, either Cast Iron ASTM A-126 CL. B or Ductile Iron, depending on model. Consult factory for details.

Additional material options available on request:
Class C Cast Iron, 2% Ni and Ni-Resist.

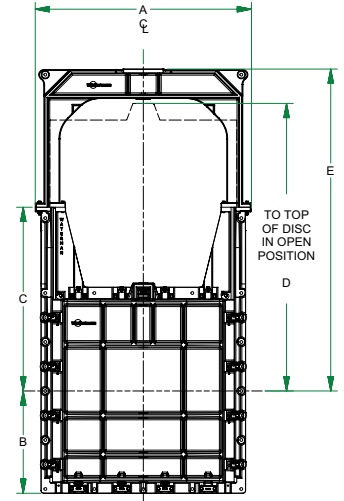

SELF CONTAINED

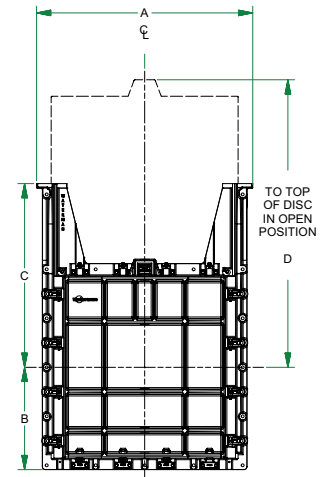

NON-SELF CONTAINED

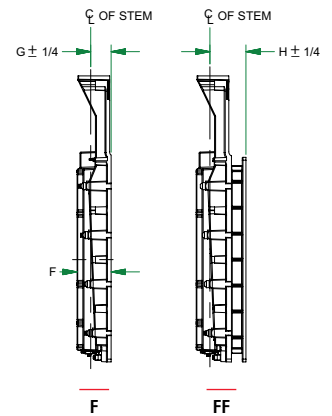

CAST GATE SIZES 21"-27"

SIZE	DESIGN HEAD FT. (M)		DIMENSIONS							
	SEAT	UNSEAT	A	B	C	D	E	F	G ± 1/4"	H ± 1/4"
21 x 21 (530 x 530)	207 (63)	113 (34)	32-3/8 (822)	15 (381)	24 (610)	34-5/8 (879)	43-1/2 (1105)	11-1/2 (292)	6-3/8 (162)	9-7/8 (251)
24 x 12 (610 x 305)	265 (81)	57 (17)	35-3/4 (908)	10-3/4 (273)	14-1/4 (362)	26 (660)	32* (813*)	11-1/2 (292)	6-1/2 (165)	9-1/2 (241)
24 x 18 (610 x 460)	244 (89)	89 (27)	35 (889)	14-1/4 (362)	19-1/8 (486)	35-1/4 (895)	37-1/4 (946)	11-3/4 (298)	7 (178)	10-3/4 (273)
24 x 24 (610 x 610)	30 (9)	6 (2)	33 (838)	16-1/2 (419)	25-3/4 (654)	42-3/4 (1086)	N/A	7 (178)	4-7/16 (113)	N/A
24 x 24 (610 x 610)	30 (9)	6 (2)	34-3/4 (883)	16-1/2 (419)	26-1/2 (673)	42-3/4 (1086)	48-1/8 (1222)	7-3/4 (197)	5-3/16 (132)	11-1/2 (292)
24 x 24 (610 x 610)	65 (20)	37.5 (11)	34-3/4 (883)	16-3/4 (425)	26-1/2 (673)	44 (1118)	48-1/8 (1222)	8-1/8 (206)	5-3/16 (132)	11-1/2 (292)
24 x 24 (610 x 610)	80.1 (24)	20.8 (6)	33 (838)	16-1/2 (419)	26 (660)	42-3/8 (1076)	48-3/16 (1224)	8-1/4 (210)	4-3/4 (121)	8-1/2 (216)
24 x 24 (610 x 610)	218 (66)	53 (16)	35 (889)	16-3/4 (425)	29 (737)	43-3/4 (1111)	46 (1168)	11-1/2 (292)	7-1/2 (191)	11-1/2 (292)
24 x 24 (610 x 610)	299 (91)	91 (28)	37-1/2 (953)	16-3/4 (425)	28-1/2 (724)	43 (1092)	49 (1245)	10-1/2 (267)	8 (203)	12-1/2 (318)
24 x 30 (610 x 760)	260 (79)	59 (18)	34-7/8 (886)	19-3/4 (502)	37-1/16 (941)	53 (1346)	62-1/2 (1588)	11-1/8 (283)	7-1/4 (184)	11-1/4 (286)
24 x 36 (610 x 915)	76 (23)	27 (8)	35 (889)	22-1/2 (572)	38 (965)	62 (1575)	63-1/2 (1613)	12-1/2 (318)	7 (178)	10-3/4 (273)
24 x 36 (610 x 915)	238 (73)	81 (25)	35 (889)	22-1/2 (572)	38 (965)	62-1/8 (1578)	63-1/2 (1613)	14 (356)	8-1/8 (206)	12-7/16 (316)
24 x 42 (610 x 1070)	194 (59)	62 (19)	35 (889)	26-1/2 (673)	47-1/4 (1200)	70 (1778)	76* (1930*)	12-1/2 (318)	7 (178)	11-1/2 (292)
24 x 48 (610 x 1220)	133 (41)	44 (13)	35-1/2 (902)	29 (737)	50 (1270)	79-3/4 (2026)	81 (2057)	14 (356)	7 (178)	10-3/4 (273)
24 x 60 (610 x 1520)	123 (37)	35 (11)	34-3/4 (883)	34-3/4 (883)	64-1/4 (1632)	98-3/8 (2499)	104-3/8* (2651*)	12-7/8 (327)	7-1/2 (191)	11-1/2 (292)
27-1/2 x 27-1/2 (700 x 700)	102.5 (31)	41.1 (13)	36-5/8 (930)	18-5/16 (465)	29-1/2 (749)	47-3/4 (1213)	53-9/16 (1360)	8-7/8 (225)	4-3/4 (121)	8-1/2 (216)

NOTES:

* To top of fabricated yoke.

Seating and Unseating values are based on standard casting material, either Cast Iron ASTM A-126 CL. B or Ductile Iron, depending on model. Consult factory for details.

Additional material options available on request:
Class C Cast Iron, 2% Ni and Ni-Resist.

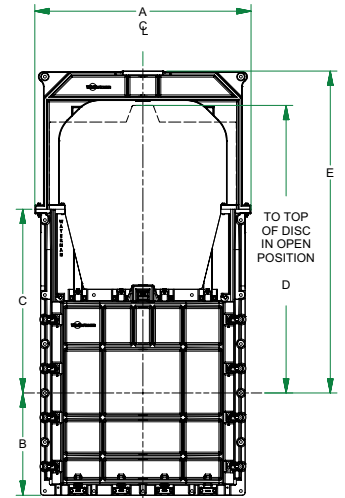

SELF CONTAINED

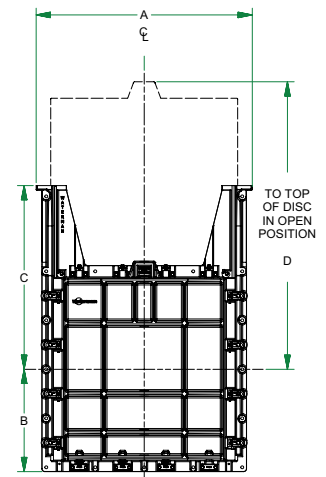

NON-SELF CONTAINED

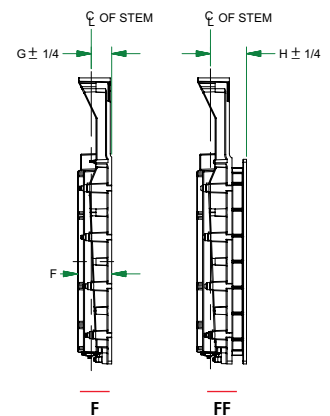

CAST GATE SIZES 30"-35"

SIZE	DESIGN HEAD FT. (M)		DIMENSIONS							
	SEAT	UNSEAT	A	B	C	D	E	F	G ± 1/4"	H ± 1/4"
30 x 12 (760 x 305)	135 (41)	42 (13)	41 (1041)	10-1/2 (267)	14-1/4 (362)	26 (660)	31-3/8 (797)	10 (254)	7 (178)	11-1/2 (292)
30 x 24 (760 x 610)	144 (44)	48 (15)	41 (1041)	17-1/4 (438)	28-3/4 (730)	44-1/8 (1121)	46 (1168)	10 (254)	7 (178)	11-1/2 (292)
30 x 30 (760 x 760)	30 (9)	6 (2)	39 (991)	19-1/2 (495)	34-11/16 (881)	51-7/8 (1318)	N/A	7-11/16 (195)	4-15/16 (125)	N/A
30 x 30 (760 x 760)	30 (9)	6 (2)	42 (1067)	20 (508)	38-1/8 (968)	51-7/8 (1318)	57-1/4 (1454)	8-11/16 (221)	5-15/16 (151)	11-1/2 (292)
30 x 30 (760 x 760)	105.4 (32)	21.1 (6)	39 (991)	19-1/2 (495)	32 (813)	51-3/8 (1305)	57-3/16 (1453)	8-7/8 (225)	5 (127)	8-3/4 (222)
30 x 30 (760 x 760)	160 (49)	56 (17)	42-3/8 (1076)	19-3/4 (502)	37-5/8 (956)	53 (1346)	55 (1397)	12-1/2 (318)	7 (178)	11-1/2 (292)
30 x 30 (760 x 760)	220 (67)	50 (15)	42 (1067)	20 (508)	38-1/8 (968)	53 (1346)	57-1/4 (1454)	9-7/8 (251)	5-15/16 (151)	11-1/2 (292)
30 x 30 (760 x 760)	230 (70)	82 (25)	44-1/4 (1124)	20 (508)	37-1/2 (953)	52 (1321)	58-3/4 (1492)	13-3/4 (349)	8 (203)	12 (305)
30 x 36 (760 x 910)	66 (20)	16 (5)	40-1/2 (1029)	23-1/4 (591)	41-7/16 (1053)	62-5/8 (1591)	64-3/4 (1645)	11-1/2 (292)	7-1/8 (181)	11-5/8 (295)
30 x 42 (760 x 1070)	153 (47)	65 (20)	42 (1067)	26-1/2 (673)	47-1/2 (1207)	71-1/4 (1810)	73-1/2 (1867)	12-1/2 (318)	8 (203)	12 (305)
30 x 48 (760 x 1220)	100 (30)	23 (7)	41 (1041)	29 (737)	51-1/4 (1302)	78 (1981)	85* (2159*)	9 (229)	8 (203)	12 (305)
30 x 48 (760 x 1220)	150 (46)	51 (16)	42-1/8 (1070)	29-1/2 (749)	51-1/4 (1302)	79-3/4 (2026)	88-1/4* (2242*)	14 (356)	8 (203)	12 (305)
30 x 54 (760 x 1370)	87 (27)	25 (8)	42-3/8 (1076)	32-1/4 (819)	66-1/4 (1683)	89-1/4 (2267)	96-3/4* (2457*)	12-1/2 (318)	8 (203)	12 (305)
30 x 60 (760 x 1520)	129 (39)	49 (15)	46 (1168)	36 (914)	64 (1626)	100-7/8 (2562)	104 (2642)	15-1/2 (394)	8 (203)	12-1/2 (318)
31-1/2 x 31-1/2 (800 x 800)	69.8 (21)	25.2 (8)	40-9/16 (1030)	20-1/4 (514)	33-7/8 (860)	53-5/8 (1362)	60-1/4 (1530)	8-7/8 (225)	5 (127)	8-3/4 (222)
35-1/2 x 86-1/2 (900 x 2200)	117 (36)	36 (11)	50 (1270)	49-1/4 (1250)	89-7/8 (2283)	139-1/2 (3541)	158-1/4 (4020)	14-3/8 (365)	8-1/8 (207)	N/A

NOTES:

* To top of fabricated yoke.

Seating and Unseating values are based on standard casting material, either Cast Iron ASTM A-126 CL. B or Ductile Iron, depending on model. Consult factory for details.

Additional material options available on request:
Class C Cast Iron, 2% Ni and Ni-Resist.

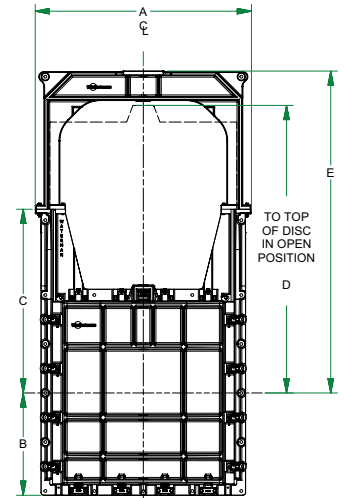

SELF CONTAINED

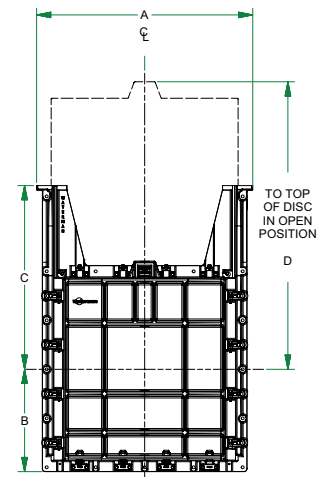

NON-SELF CONTAINED

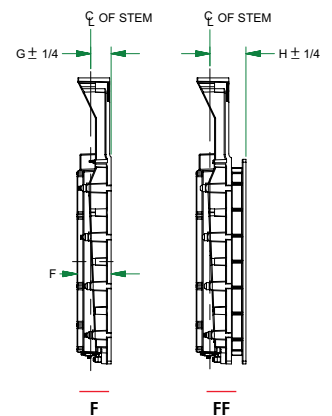

CAST GATE SIZES 36"-39"

SIZE	DESIGN HEAD FT. (M)		DIMENSIONS							
	SEAT	UNSEAT	A	B	C	D	E	F	G ± 1/4"	H ± 1/4"
36 x 18 (910 x 460)	127 (39)	25 (8)	47-7/8 (1216)	13-3/4 (349)	20-3/4 (527)	34 (864)	41* (1041*)	12-1/2 (318)	7 (178)	11 (279)
36 x 24 (910 x 610)	142 (43)	41 (12)	47-7/8 (1216)	16-3/4 (425)	28-1/2 (724)	43 (1092)	50* (1270*)	12-1/2 (318)	7 (178)	11 (279)
36 x 36 (910 x 910)	30 (9)	6 (2)	45 (1143)	22-1/2 (572)	41-9/16 (1056)	61 (1549)	N/A	7-11/16 (195)	4-7/8 (124)	N/A
36 x 36 (910 x 910)	30 (9)	6 (2)	48 (1219)	22-1/2 (572)	41-9/16 (1056)	61 (1549)	69-11/16 (1770)	8-11/16 (221)	5-7/8 (149)	11-7/16 (291)
36 x 36 (915 x 915)	60.5 (18)	20.2 (6)	45 (1143)	22-1/2 (572)	39 (991)	60-3/8 (1534)	66-3/16 (1681)	8-7/8 (225)	5 (127)	8-3/4 (222)
36 x 36 (910 x 910)	135 (41)	31 (9)	48 (1219)	22-1/2 (572)	41-1/2 (1054)	63 (1600)	66 (1676)	12-1/2 (318)	7 (178)	11-1/2 (292)
36 x 36 (910 x 910)	180 (55)	35 (11)	48 (1219)	22-1/8 (587)	41-9/16 (1056)	62-1/8 (1578)	69-11/16 (1770)	10-3/8 (264)	5-15/16 (151)	11-1/2 (292)
36 x 36 (910 x 910)	263 (80)	95 (29)	50 (1270)	23 (584)	41-1/2 (1054)	61 (1549)	66-3/4 (1695)	12 (305)	8-1/2 (216)	12-1/2 (318)
36 x 42 (910 x 1070)	63 (19)	23 (7)	47-3/8 (1203)	26 (660)	47-1/2 (1207)	63 (1600)	70* (1778*)	12-1/2 (318)	8 (203)	12 (305)
36 x 48 (910 x 1220)	96 (29)	31 (9)	48-5/8 (1235)	29-1/2 (749)	51-1/4 (1302)	79-3/4 (2026)	87-3/4* (2229*)	14 (356)	8 (203)	12 (305)
36 x 60 (910 x 1520)	96 (29)	30 (9)	52 (1321)	36 (914)	64-1/4 (1632)	98-3/8 (2499)	109* (2769*)	13-3/4 (349)	8 (203)	12-1/2 (318)
36 x 60 (910 x 1520)	120 (37)	25 (8)	49 (1245)	35-1/2 (902)	64-1/2 (1638)	99-1/4 (2521)	-	10-1/4 (260)	6-5/8 (168)	12-1/2 (318)
36 x 72 (910 x 1830)	70 (21)	29 (9)	52 (1321)	42 (1067)	74 (1880)	118-7/8 (3019)	126-7/8* (3223*)	15-1/2 (394)	8 (203)	12-1/2 (318)
39-3/8 x 35-7/16 (1000 x 900)	66.8 (20)	26.1 (8)	48-7/16 (1230)	22-1/4 (565)	37-1/2 (953)	59-1/2 (1511)	63-3/8 (1610)	8-3/4 (222)	5 (127)	8-3/4 (222)
39-3/8 x 39-3/8 (1000 x 1000)	30 (9)	6 (2)	49-3/8 (1254)	24-11/16 (627)	42-5/16 (1075)	66-1/8 (1680)	N/A	8-1/2 (216)	5 (127)	N/A
39-3/8 x 39-3/8 (1000 x 1000)	30 (9)	6 (2)	57 (1448)	24-3/16 (614)	47 (1194)	66-1/8 (1680)	77-1/4 (1962)	9-9/16 (243)	5-13/16 (148)	11-1/16 (281)
39-3/8 x 39-3/8 (1000 x 1000)	66.8 (20)	26.1 (8)	48-7/16 (1230)	24-1/4 (616)	41-5/16 (1049)	65-1/8 (1654)	71-1/4 (1810)	8-3/4 (222)	5 (127)	8-3/4 (222)
39-3/8 x 39-3/8 (1000 x 1000)	150 (46)	45 (14)	57 (1448)	25 (635)	47 (1194)	67-7/8 (1724)	77-1/4 (1962)	10-1/16 (256)	5-7/8 (149)	11-1/8 (283)

NOTES:

* To top of fabricated yoke.

Seating and Unseating values are based on standard casting material, either Cast Iron ASTM A-126 CL. B or Ductile Iron, depending on model. Consult factory for details.

Additional material options available on request:
Class C Cast Iron, 2% Ni and Ni-Resist.

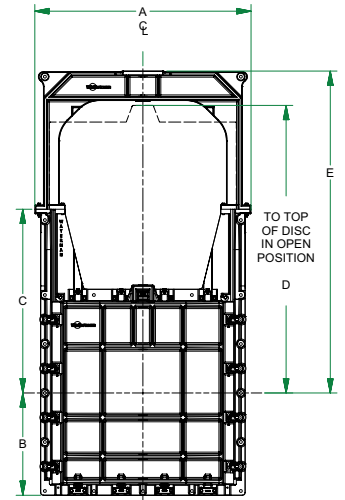

SELF CONTAINED

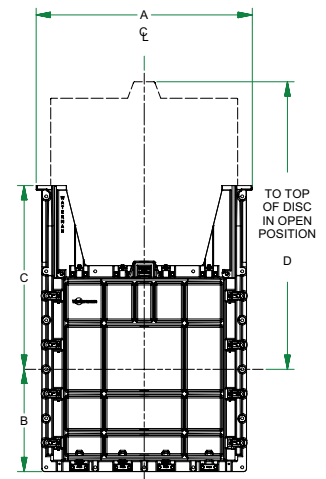

NON-SELF CONTAINED

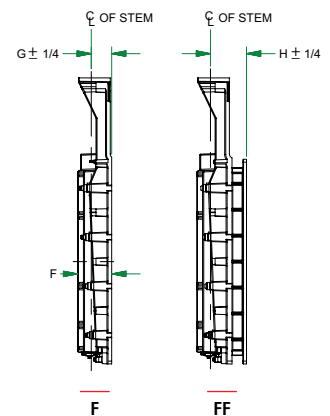

CAST GATE SIZES 42"

SIZE	DESIGN HEAD FT. (M)		DIMENSIONS							
	SEAT	UNSEAT	A	B	C	D	E	F	G ± 1/4"	H ± 1/4"
42 x 18 (1070 x 460)	84 (26)	30 (9)	53-3/4 (1365)	14-1/4 (362)	20-3/4 (527)	35-3/8 (899)	49-1/4 (1251)	10-3/8 (264)	7-3/4 (197)	9-3/4 (248)
42 x 42 (1070 x 1070)	30 (9)	6 (2)	52 (1321)	26 (660)	44 9/16 (1132)	70 (1778)	N/A	8-1/2 (216)	5 (127)	N/A
42 x 42 (1070 x 1070)	30 (9)	6 (2)	57 (1448)	26-1/4 (667)	47-9/16 (1208)	70 (1778)	77-13/16 (1976)	9-9/16 (243)	5-13/16 (148)	11-15/16 (303)
42 x 42 (1070 x 1070)	62 (19)	20 (6)	53-3/4 (1365)	26-1/2 (673)	47 (1194)	71-1/4 (1810)	76 (1930)	12-1/2 (318)	8 (203)	12 (305)
42 x 42 (1070 x 1070)	73.4 (22)	21.9 (7)	51 (1295)	25-1/2 (648)	44 (1118)	70-1/2 (1791)	77-3/4 (1975)	9-3/4 (248)	6-1/4 (159)	10-3/4 (273)
42 x 42 (1070 x 1070)	143 (44)	38 (12)	57 (1448)	26-1/4 (667)	47-9/16 (1208)	71-1/8 (1807)	77-13/16 (1976)	9-7/8 (251)	5-7/8 (149)	12 (305)
42 x 42 (1070 x 1070)	170 (52)	51 (16)	56 (1422)	26-1/2 (673)	47-1/2 (1207)	70 (1778)	77-1/2 (1969)	12 (305)	8 (203)	12 (305)
42 x 54 (1070 x 1370)	93 (28)	26 (8)	53-3/4 (1365)	32-1/4 (819)	66-1/4 (1683)	89-1/4 (2267)	95 (2413)	12-1/2 (318)	8 (203)	12 (305)
42 x 54 (1070 x 1370)	120 (37)	25 (8)	57 (1448)	32-1/4 (819)	66-3/4 (1695)	89-3/4 (2280)	-	10-15/16 (262)	6-1/4 (159)	12 (305)

NOTES:

* To top of fabricated yoke.

Seating and Unseating values are based on standard casting material, either Cast Iron ASTM A-126 CL. B or Ductile Iron, depending on model. Consult factory for details.

Additional material options available on request:
Class C Cast Iron, 2% Ni and Ni-Resist.

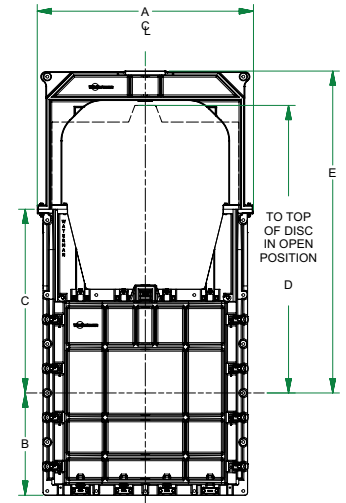

SELF CONTAINED

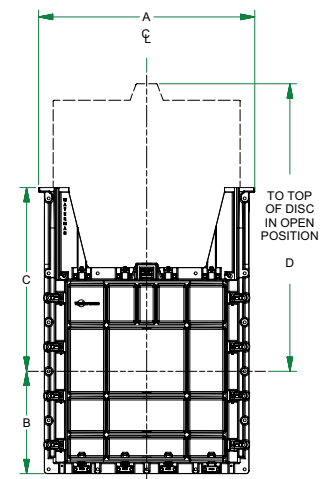

NON-SELF CONTAINED

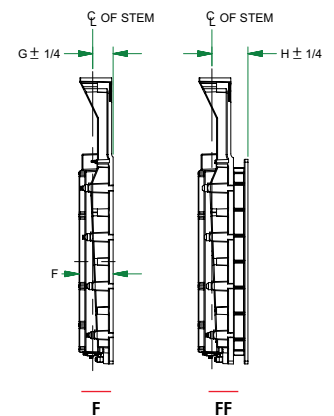

CAST GATE SIZES 48"

SIZE	DESIGN HEAD FT. (M)		DIMENSIONS								
	SEAT	UNSEAT	A	B	C	D	E	F	G ± 1/4"	H ± 1/4"	
48 x 36 (1220 x 910)	70 (21)	24 (7)	59 (1499)	23-1/2 (597)	38 (965)	61 (1549)	68* (1727*)	14 (356)	8 (203)	12 (305)	
48 x 48 (1220 x 1220)	30 (9)	6 (2)	57 (1448)	28-1/2 (724)	49-7/8 (1267)	79 (2007)	N/A	8-3/4 (222)	5-1/4 (133)	N/A	
48 x 48 (1220 x 1220)	30 (9)	6 (2)	58-3/4 (1492)	28-1/2 (724)	51-11/16 (1313)	79 (2007)	86-7/8 (2207)	9-7/8 (251)	6-1/16 (154)	12 (305)	
48 x 48 (1220 x 1220)	43 (13)	17 (5)	58-3/4 (1492)	29 (737)	51-1/4 (1302)	79-3/4 (2026)	83 (2108)	14 (356)	8 (203)	12 (305)	
48 x 48 (1220 x 1220)	49.2 (15)	15.6 (5)	57 (1448)	28-1/2 (724)	50-1/8 (1273)	79-1/2 (2019)	86-3/4 (2203)	10-3/4 (273)	6-1/4 (159)	10-3/4 (273)	
48 x 48 (1220 x 1220)	60 (18)	27.5 (8)	58-3/4 (1492)	29-1/8 (740)	51-11/16 (1313)	80 (2032)	86-7/8 (2207)	10-5/8 (270)	6 (152)	12 (305)	
48 x 48 (1220 x 1220)	196 (60)	63 (19)	63-1/2 (1613)	29 (737)	51-1/4 (1302)	80-3/4 (2051)	82-1/2 (2096)	14-3/4 (375)	8-1/2 (216)	12-1/2 (318)	
48 x 60 (1220 x 1520)	49 (15)	15 (5)	64 (1626)	36 (914)	62-1/2 (1588)	100-7/8 (2562)	102-3/4 (2610)	15-1/2 (394)	8 (203)	12 (305)	
48 x 60 (1220 x 1520)	250 (76)	73 (22)	64 (1626)	36 (914)	62-1/2 (1588)	97 (2464)	102-3/4 (2610)	12 (305)	8 (203)	12 (305)	
48 x 72 (1220 x 1830)	83 (25)	26 (8)	63-1/2 (1613)	42 (1067)	74 (1880)	117-3/4 (2991)	121-1/2 (3086)	15-1/2 (394)	9 (229)	13-1/4 (337)	
48 x 84 (1220 x 2130)	258 (79)	95 (29)	64 (1626)	48 (1219)	87 (2210)	138 (3505)	149* (3785*)	18-1/2 (470)	9-1/2 (241)	13-3/4 (349)	
48 x 96 (1220 x 2440)	167 (51)	52 (16)	69 (1753)	56 (1422)	100 (2540)	154-7/8 (3934)	164-7/8* (4188*)	18-1/2 (470)	11 (279)	15-1/4 (387)	

NOTES:

* To top of fabricated yoke.

Seating and Unseating values are based on standard casting material, either Cast Iron ASTM A-126 CL. B or Ductile Iron, depending on model. Consult factory for details.

Additional material options available on request:
Class C Cast Iron, 2% Ni and Ni-Resist.

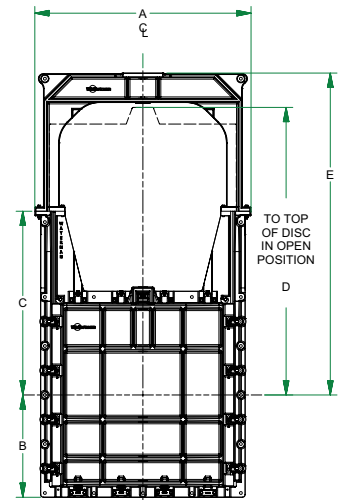

SELF CONTAINED

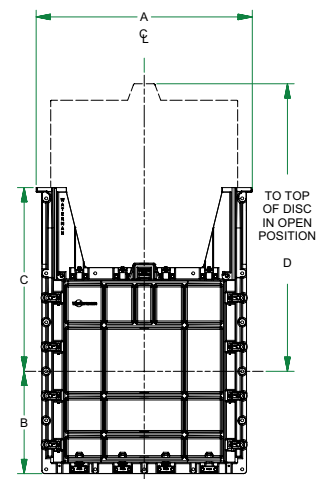

NON-SELF CONTAINED

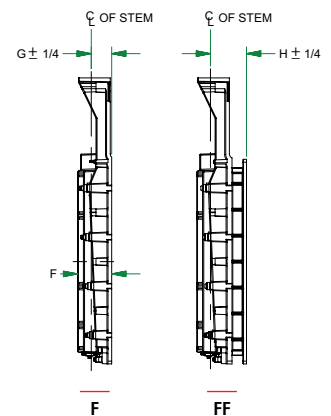

CAST GATE SIZES 54"-60"

SIZE	DESIGN HEAD FT. (M)		DIMENSIONS							
	SEAT	UNSEAT	A	B	C	D	E	F	G ± 1/4"	H ± 1/4"
54 x 48 (1370 x 1220)	65 (20)	22 (7)	69 (1753)	30 (762)	51-3/8 (1305)	80-1/2 (2045)	-	10-5/8 (270)	6-1/4 (159)	12-1/2 (318)
54 x 54 (1370 x 1370)	30 (9)	6 (2)	65 (1651)	32-1/2 (826)	59-1/16 (1500)	88 (2235)	N/A	9-1/2 (241)	5-5/16 (135)	N/A
54 x 54 (1370 x 1370)	30 (9)	6 (2)	69 (1753)	32-1/2 (826)	61-9/16 (1564)	88 (2235)	97-3/4 (2483)	10-3/4 (273)	6-9/16 (167)	12-5/8 (321)
54 x 54 (1370 x 1370)	59 (18)	21 (6)	69-1/2 (1765)	33 (838)	59-1/4 (1505)	91-7/8 (2334)	107 (2718)	15-1/2 (394)	8-5/8 (219)	12-5/8 (321)
54 x 54 (1370 x 1370)	130 (40)	28 (9)	69 (1753)	32-1/2 (826)	61-9/16 (1564)	89-3/8 (2270)	97-3/4 (2483)	11-1/16 (281)	6-1/2 (165)	12-5/8 (321)
54 x 54 (1370 x 1370)	205 (62)	75 (23)	69-1/2 (1765)	33 (838)	59-1/4 (1505)	88 (2235)	101* (2565*)	12 (305)	8-1/2 (216)	12-1/2 (318)
54 x 60 (1370 x 1520)	63 (19)	25 (8)	69-1/2 (1765)	36 (914)	64 (1626)	101 (2565)	111* (2819*)	15-1/2 (394)	8-3/4 (222)	12-1/2 (318)
54 x 84 (1370 x 2130)	44 (13)	25 (8)	70 (1778)	48 (1219)	87 (2210)	136-7/8 (3477)	146-7/8* (3731*)	14 (356)	8-1/2 (216)	12 (305)
54 x 96 (1370 x 2440)	205 (62)	84 (26)	75 (1905)	56 (1422)	100 (2540)	154-7/8 (3934)	167-7/8* (4264*)	20-3/4 (527)	11-5/8 (295)	N/A
60 x 30 (1520 x 760)	62 (19)	24 (7)	75 (1905)	21 (533)	37-5/8 (956)	54 (1372)	64* (1626*)	15-1/2 (394)	8 (203)	12 (305)
60 x 30 (1520 x 760)	120 (37)	25 (8)	75 (1905)	20-1/2 (521)	37-3/4 (959)	53-1/4 (1353)	-	10-1/4 (260)	6-3/16 (157)	12 (305)
60 x 36 (1520 x 910)	55 (17)	17 (5)	76 (1930)	24 (610)	38 (965)	64-7/8 (1648)	74-7/8* (1902*)	15-1/2 (394)	8 (203)	12 (305)
60 x 48 (1520 x 1220)	31 (9)	11 (3)	75-3/4 (1924)	30 (762)	52-1/2 (1334)	83 (2108)	93* (2362*)	15-1/2 (394)	8-1/2 (216)	12-1/2 (318)
60 x 48 (1520 x 1220)	120 (36)	63 (19)	75 (1905)	29 (737)	51-1/2 (1308)	81 (2057)	87* (2210*)	15 (381)	8-1/2 (216)	12-1/2 (318)
60 x 60 (1520 x 1520)	30 (9)	6 (2)	71 (1803)	35-1/2 (902)	62-13/16 (1595)	98 (2489)	N/A	9-1/2 (241)	5-7/8 (149)	N/A
60 x 60 (1520 x 1520)	30 (9)	6 (2)	75 (1905)	35-1/2 (902)	64-1/2 (1638)	98 (2489)	111-11/16 (2837)	11-1/2 (292)	7-1/8 (181)	12-9/16 (319)
60 x 60 (1520 x 1520)	71 (22)	29 (9)	75 (1905)	36 (914)	64 (1626)	100-7/8 (2562)	116 (2946)	15-1/2 (394)	8-3/4 (222)	12-1/2 (318)
60 x 60 (1520 x 1520)	120 (37)	30 (9)	75 (1905)	35-1/2 (902)	64-1/2 (1638)	99-3/4 (2534)	111-11/16 (2837)	11-13/16 (300)	7-1/16 (179)	12-1/2 (318)
60 x 60 (1520 x 1520)	126 (38)	40 (12)	75 (1905)	36 (914)	64 (1626)	100-7/8 (2562)	116 (2946)	15-1/2 (394)	9 (229)	13-1/2 (343)
60 x 72 (1520 x 1830)	48 (15)	17 (5)	76 (1930)	42 (1067)	74 (1880)	118-7/8 (3019)	128-7/8* (3273*)	15-1/2 (394)	9 (229)	13-1/4 (337)
60 x 72 (1520 x 1830)	186 (57)	58 (18)	75-11/16 (1922)	41-3/8 (1051)	74 (1880)	117-1/4 (2978)	133-1/4* (3385*)	17 (432)	N/A	9-3/4 (248)
60 x 84 (1520 x 2130)	62 (19)	22 (7)	75 (1905)	48 (1219)	87 (2210)	136-7/8 (3477)	152-7/8* (3883*)	18-1/2 (470)	8-5/8 (219)	12 (305)
60 x 84 (1520 x 2130)	137 (42)	50 (15)	79 (2007)	50 (1270)	87 (2210)	133 (3378)	149* (3785*)	18-1/2 (470)	12 (305)	15-1/2 (394)

NOTES:

* To top of fabricated yoke.

Seating and Unseating values are based on standard casting material, either Cast Iron ASTM A-126 CL. B or Ductile Iron, depending on model. Consult factory for details.

Additional material options available on request:
Class C Cast Iron, 2% Ni and Ni-Resist.

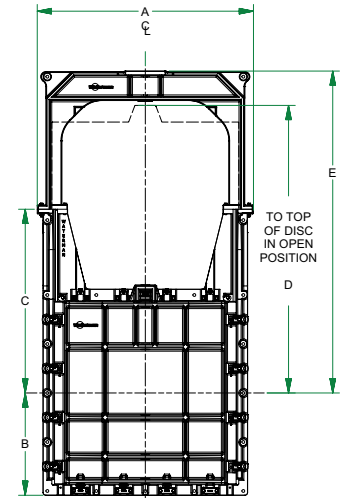

SELF CONTAINED

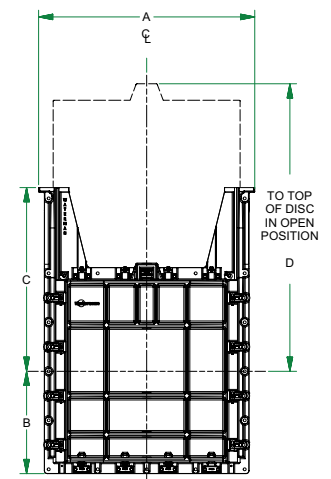

NON-SELF CONTAINED

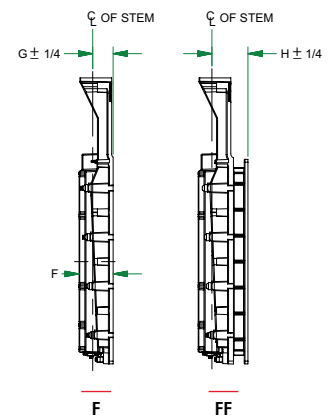

CAST GATE SIZES 66"-78"

SIZE	DESIGN HEAD FT. (M)		DIMENSIONS							
	SEAT	UNSEAT	A	B	C	D	E	F	G ± 1/4"	H ± 1/4"
66 x 66 (1680 x 1680)	30 (9)	6 (2)	78 (1981)	39 (991)	68-3/4 (1746)	107 (2718)	N/A	9-11/16 (246)	6 (152)	N/A
66 x 66 (1680 x 1680)	30 (9)	6 (2)	81 (2057)	38-1/2 (978)	69-11/16 (1770)	107 (2718)	122 (3099)	12 (305)	7-5/8 (194)	12-1/2 (318)
66 x 66 (1680 x 1680)	31 (9)	11 (3)	81-1/4 (2064)	39 (991)	69-1/2 (1765)	107-3/4 (2737)	127-1/2* (3239*)	15-1/2 (394)	9 (229)	12-1/2 (318)
66 x 66 (1680 x 1680)	85 (26)	30 (9)	81 (2057)	38-1/2 (978)	69-11/16 (1770)	109 (2769)	122 (3099)	12-1/2 (318)	7-5/8 (194)	12-1/2 (318)
66 x 66 (1680 x 1680)	102 (31)	41 (12)	80 (2032)	39 (991)	68 (1727)	107-3/4 (2737)	126-1/2* (3213*)	15-1/2 (394)	9 (229)	13-1/2 (343)
72 x 48 (1830 x 1220)	29 (9)	13 (4)	88-1/4 (2242)	30 (762)	51-1/2 (1308)	80-3/4 (2051)	89-1/4* (2267*)	15-1/2 (394)	9 (229)	13 (330)
72 x 48 (1830 x 1220)	157 (47)	68 (20)	88 (2235)	29 (736)	51-1/2 (1308)	81 (2057)	87* (2210*)	16 (406)	9-1/2 (241)	13-1/2 (343)
72 x 60 (1830 x 1520)	37 (11)	12 (4)	87 (2210)	36 (914)	63-1/4 (1607)	100-7/8 (2562)	109-3/8* (2778*)	15-1/2 (394)	9 (229)	13-1/4 (337)
72 x 72 (1830 x 1830)	30 (9)	6 (2)	83 (2108)	41-1/2 (1054)	74-7/8 (1902)	116-7/8 (2969)	N/A	11 (279)	6-3/8 (162)	N/A
72 x 72 (1830 x 1830)	30 (9)	6 (2)	88 (2235)	42 (1067)	76-1/8 (1934)	116-7/8 (2969)	131-3/8 (3337)	13-3/16 (335)	8-3/8 (213)	13-1/2 (343)
72 x 72 (1830 x 1830)	51 (16)	17 (5)	88 (2235)	42 (1067)	74-3/8 (1889)	117-3/4 (2991)	135-1/4 (3435)	16-3/4 (425)	9-1/4 (235)	13-1/4 (337)
72 x 72 (1830 x 1830)	75 (23)	49 (15)	88 (2235)	42 (1067)	76-1/8 (1934)	119-3/16 (3027)	131-3/8 (3337)	13-3/8 (340)	8-5/16 (211)	13-1/4 (337)
72 x 72 (1830 x 1830)	157 (48)	50 (15)	88 (2235)	42 (1067)	74-3/8 (1889)	117-3/4 (2991)	133-3/4* (3399*)	16-3/4 (425)	9-1/4 (235)	13-1/4 (337)
72 x 84 (1830 x 2130)	70 (21)	25 (8)	88 (2235)	47-7/8 (1216)	87 (2210)	136-7/8 (3477)	146-7/8* (3731*)	18-1/2 (470)	9-3/4 (248)	13-3/4 (349)
72 x 96 (1830 x 2440)	83 (25)	23 (7)	92 (2337)	56 (1422)	100 (2540)	154-7/8 (3934)	167-7/8* (4264)	19 (483)	12 (305)	17 (432)
72 x 108 (1830 x 2740)	90 (27)	39 (12)	92 (2337)	62 (1575)	110 (2794)	172-7/8 (4391)	183-7/8* (4670*)	14 (356)	11-1/4 (286)	16-1/4 (413)
72 x 120 (1830 x 3050)	78 (24)	21 (6)	92 (2337)	68 (1727)	124-1/2 (3162)	190-7/8 (4848)	203-7/8* (5178*)	20 (508)	12-3/4 (324)	17-3/4 (451)
72 x 120 (1830 x 3050)	130 (40)	46 (14)	92 (2337)	68 (1727)	124-1/2 (3162)	190-7/8 (4848)	206-7/8* (5255*)	20-1/2 (521)	12-3/4 (324)	17-3/4 (451)
78 x 78 (1980 x 1980)	62 (19)	19 (6)	96-3/4 (2457)	45 (1143)	82 (2083)	127-7/8 (3248)	150-3/4 (3829)	15-1/2 (394)	9 (229)	13-3/4 (349)
78 x 78 (1980 x 1980)	108 (33)	42 (13)	94-1/4 (2394)	45-1/4 (1150)	85-11/16 (2176)	127-9/16 (3241)	154-3/4 (3930)	18-1/8 (460)	9-5/8 (244)	14-3/8 (365)
78-3/4 x 78-3/4 (2000 x 2000)	62 (19)	18 (5)	94-1/4 (2394)	45-1/4 (1150)	85-11/16 (2176)	127-1/2 (3240)	154 (3910)	16-1/8 (410)	9-11/16 (245)	14-3/8 (365)
78.74 x 78.74 (2000 x 2000)	108 (33)	42 (13)	94-1/4 (2394)	45-1/4 (1150)	86-3/16 (2189)	127-1/2 (3240)	115-3/8 (2930)	18-1/8 (460)	9-5/8 (245)	14-3/8 (365)
78-3/4 x 86-5/8 (2000 x 2200)	61 (19)	20 (6)	94-1/4 (2394)	49-1/4 (1250)	89-7/8 (2283)	139-1/2 (3541)	158-1/4 (4020)	16-1/8 (410)	9-11/16 (245)	14-3/8 (365)

NOTES:

* To top of fabricated yoke.

Seating and Unseating values are based on standard casting material, either Cast Iron ASTM A-126 CL. B or Ductile Iron, depending on model. Consult factory for details.

Additional material options available on request:
Class C Cast Iron, 2% Ni and Ni-Resist.

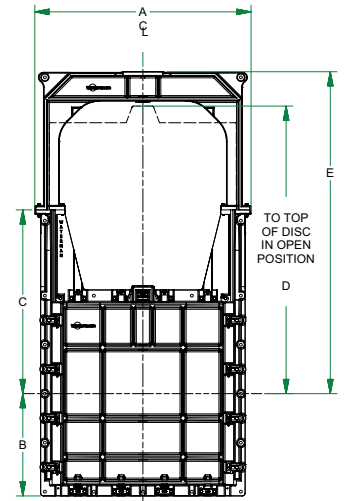

SELF CONTAINED

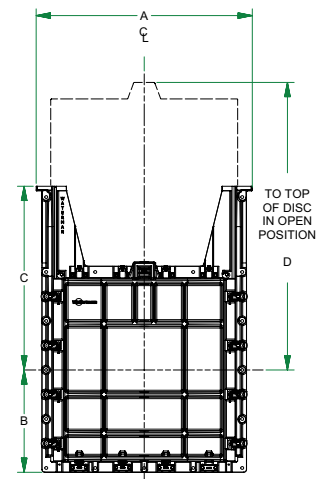

NON-SELF CONTAINED

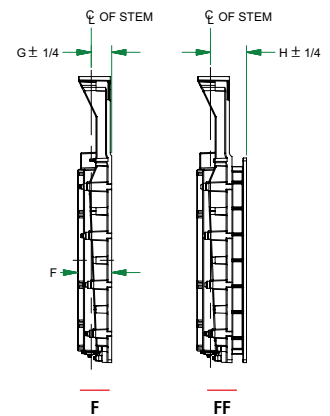

CAST GATE SIZES 84"-96"

SIZE	DESIGN HEAD FT. (M)		DIMENSIONS							
	SEAT	UNSEAT	A	B	C	D	E	F	G ± 1/4"	H ± 1/4"
84 x 36 (2130 x 910)	63 (19)	20 (6)	100 (2540)	24 (610)	43-1/2 (1105)	63-5/8 (1616)	76-5/8* (1946*)	14-1/2 (368)	8 (203)	12-1/2 (318)
84 x 48 (2130 x 1220)	46 (14)	17 (5)	100 (2540)	30 (762)	52 (1321)	82-7/8 (2105)	95-7/8* (2435*)	18-1/2 (470)	8 (203)	12-1/2 (318)
84 x 60 (2130 x 1520)	130 (40)	50 (15)	112 (2845)	38-1/2 (978)	104 (2642)	103 (2616)	119* (3023*)	22 (559)	12-3/4 (324)	N/A
84 x 60 (2130 x 1520)	173 (53)	67 (20)	103-1/2 (2629)	36 (914)	64 (1626)	97 (2464)	112-3/8 (2854)	18-1/2 (470)	8-1/2 (216)	12 (305)
84 x 72 (2130 x 1830)	58 (18)	21 (6)	100 (2540)	42 (1067)	74-3/8 (1889)	117-3/4 (2991)	130-3/4* (3321*)	18-1/2 (470)	9-1/2 (241)	13-3/4 (349)
84 x 84 (2130 x 2130)	70 (21)	31 (10)	100 (2540)	47-1/2 (1207)	87 (2210)	136-7/8 (3477)	149-7/8* (3807*)	18-1/2 (470)	9-1/2 (241)	13-3/4 (349)
84 x 84 (2130 x 2130)	161 (49)	59 (18)	98 (2489)	47-1/2 (1207)	87 (2210)	133 (3378)	149* (3785*)	18-1/2 (470)	9-1/2 (241)	13-3/4 (349)
84 x 108 (2130 x 2740)	88 (27)	28 (9)	104 (2642)	62 (1575)	110 (2794)	172-7/8 (4391)	188-7/8* (4797*)	14 (356)	11-1/4 (286)	16-1/4 (413)
84 x 120 (2130 x 3050)	67 (20)	14 (4)	104-1/4 (2648)	68 (1727)	124-1/2 (3162)	190-7/8 (4848)	206-7/8* (5255*)	20 (508)	12-3/4 (324)	17 (432)
90 x 90 (2290 x 2290)	82 (25)	31 (9)	111 (2819)	53 (1346)	110 (2794)	145-7/8 (3705)	161-7/8* (4112*)	18-1/2 (470)	11 (279)	15-1/4 (387)
96 x 36 (2440 x 910)	39 (12)	14 (4)	117 (2972)	24 (610)	41-1/2 (1054)	63-3/4 (1619)	79-3/4* (2026*)	18-1/2 (470)	10-1/2 (267)	14-1/2 (368)
96 x 60 (2440 x 1520)	37 (11)	15 (5)	111 (2819)	36 (914)	64 (1626)	100-7/8 (2562)	116-7/8* (2969*)	18-1/2 (470)	11 (279)	15-1/4 (387)
96 x 72 (2440 x 1830)	55 (17)	20 (6)	117 (2972)	44 (1118)	74 (1880)	118-7/8 (3019)	134-7/8* (3426*)	20 (508)	11 (279)	15-1/2 (394)
96 x 78 (2440 x 1980)	64 (20)	21 (6)	117 (2972)	47 (1194)	82-1/2 (2096)	127-7/8 (3248)	143-7/8* (3654*)	18-1/2 (470)	11 (279)	15-1/4 (387)
96 x 96 (2440 x 2440)	65 (20)	21 (6)	117 (2972)	56 (1422)	100 (2540)	151 (3835)	171* (4343*)	18-1/2 (470)	11-1/2 (292)	15-1/4 (387)
96 x 96 (2440 x 2440)	97 (30)	41 (12)	117 (2972)	56 (1422)	100 (2540)	154-7/8 (3934)	170-7/8* (4340*)	19 (483)	12 (305)	17 (432)
96 x 120 (2440 x 3050)	51 (16)	10 (3)	116 (2946)	68 (1727)	124 (3150)	190-7/8 (4848)	206-7/8* (5255*)	20 (508)	12-3/4 (324)	17 (432)

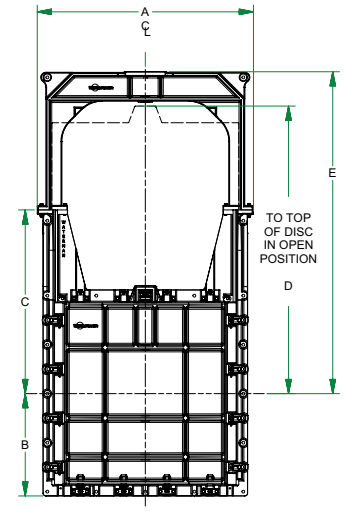

SELF CONTAINED

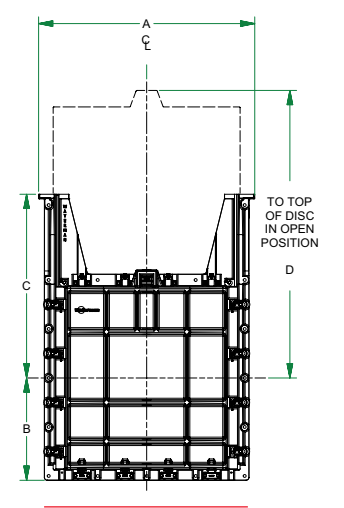

NON-SELF CONTAINED

NOTES:

* To top of fabricated yoke.

Seating and Unseating values are based on standard casting material, either Cast Iron ASTM A-126 CL. B or Ductile Iron, depending on model. Consult factory for details.

Additional material options available on request:
Class C Cast Iron, 2% Ni and Ni-Resist.

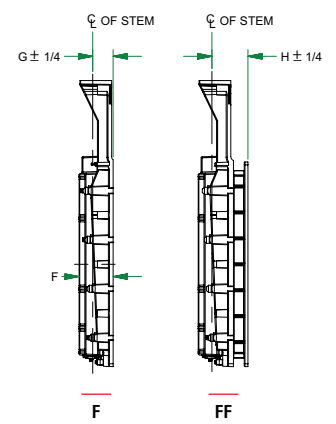

CAST GATE SIZES 102"-132"

SIZE	DESIGN HEAD FT. (M)		DIMENSIONS							
	SEAT	UNSEAT	A	B	C	D	E	F	G ± 1/4"	H ± 1/4"
102 x 78 (2590 x 1980)	50 (15)	33 (10)	118 (2997)	45 (1143)	82 (2083)	127-7/8 (3248)	143-7/8* (3654*)	20 (508)	11 (279)	16 (406)
108 x 108 (2740 x 2740)	53 (16)	17 (5)	128 (3251)	62 (1575)	110 (2794)	172-7/8 (4391)	191-7/8* (4874*)	14 (356)	11-1/4 (286)	16-1/4 (413)
108 x 120 (2740 x 3050)	41 (12)	7 (2)	126 (3200)	68 (1727)	124-1/2 (3162)	190-7/8 (4848)	210* (5334*)	20 (508)	12-3/4 (324)	17 (432)
108 x 144 (2740 x 3660)	63 (19)	20 (6)	130-1/4 (3308)	80 (2032)	150 (3810)	226-3/4 (5759)	245-7/8* (6245*)	20-3/4 (527)	12-1/2 (318)	18 (457)
120 x 60 (3050 x 1520)	29 (9)	9 (3)	140 (3556)	38 (965)	64 (1626)	100-7/8 (2562)	116-7/8* (2969*)	18-1/2 (470)	11 (279)	15-1/4 (387)
120 x 72 (3050 x 1830)	55 (17)	20 (6)	140 (3556)	44 (1118)	74 (1880)	118-7/8 (3019)	134-1/4* (3410*)	20 (508)	11 (279)	15-1/2 (394)
120 x 96 (3050 x 2440)	31 (9)	6 (2)	140 (3556)	56 (1422)	100 (2540)	154-7/8 (3934)	170-7/8* (4340*)	19 (483)	12 (305)	17 (432)
120 x 108 (3050 x 2740)	43 (13)	12 (4)	142 (3607)	62 (1575)	110 (2794)	172-7/8 (4391)	188-7/8* (4797*)	20 (508)	11-1/4 (286)	16-1/4 (413)
120 x 120 (3050 x 3050)	59 (18)	17 (5)	140-1/4 (3562)	68 (1727)	124-1/2 (3162)	190-7/8 (4848)	206-7/8* (5255*)	20 (508)	12-3/4 (324)	17 (432)
120 x 132 (3050 x 3350)	60 (18)	20 (6)	142 (3607)	74 (1880)	134 (3404)	208-7/8 (5305)	224-7/8* (5712*)	21-3/4 (552)	12-1/2 (318)	18 (457)
132 x 132 (3350 x 3350)	46 (14)	10 (3)	154 (3912)	74 (1880)	134 (3404)	208-7/8 (5305)	228-1/8* (5794*)	20 (508)	12-1/2 (318)	16-3/4 (425)

NOTES:

* To top of fabricated yoke.

Seating and Unseating values are based on standard casting material, either Cast Iron ASTM A-126 CL. B or Ductile Iron, depending on model. Consult factory for details.

Additional material options available on request:
Class C Cast Iron, 2% Ni and Ni-Resist.

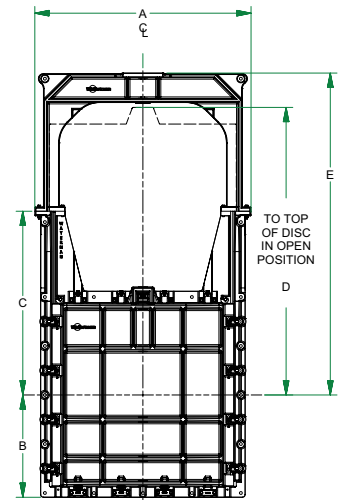

SELF CONTAINED

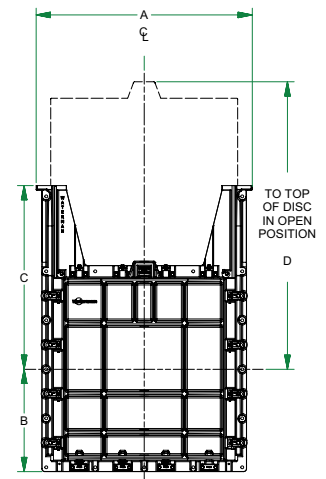

NON-SELF CONTAINED

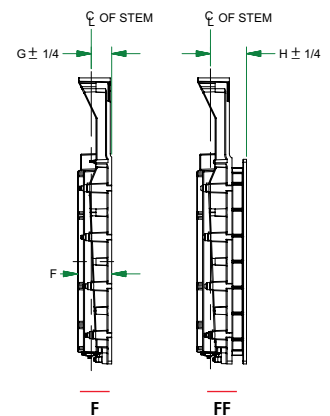

SECTION _____

TYPICAL SPECIFICATIONS FOR CAST IRON SLUICE GATE(S)

PART 1 GENERAL

1.01 SCOPE OF WORK

- A. The equipment provided under this section shall be fabricated, assembled, erected, and placed in proper operating condition in full conformity with the drawings, specifications, engineering data, instructions, and recommendations of the equipment manufacturer unless exceptions are noted by the engineer.

Gates and operators shall be supplied with all the necessary parts and accessories indicated on the drawings, specified or otherwise required for a complete and properly operating installation, and shall be the latest standard product of a manufacturer regularly engaged in the production of cast iron water control gates.

- B. Unit Responsibility: To insure compatibility of all components directly related to the sluice gates, unit responsibility for the sluice gates, actuators, and accessories as described in this section shall be the responsibility of the sluice gate manufacturer unless specified otherwise.

1.02 SUBMITTALS

- A. Submittals shall be in accordance with Sections _____ and as specified herein.

Submittals shall include as a minimum:

1. Shop Drawings
2. Manufacturer's operation and maintenance manuals and information.
3. Manufacturer's installation certificate.
4. Manufacturer's equipment warranty.
5. Manufacturer's performance affidavit in accordance with Section _____.
6. Design calculations demonstrating lift loads and deflection in conformance to the application requirements.
Design calculations shall be approved by a licensed engineer (PE) and shall be available upon request.

1.03 QUALITY ASSURANCE

A. Qualifications

1. All of the equipment specified under this Section shall be furnished by a single manufacturer with a minimum of 20-years of experience designing and manufacturing cast iron sluice gates. The manufacturer shall have manufactured cast iron sluice gates of the type described herein for a minimum of 20 similar projects.
2. The project design is based on the Waterman Heavy Duty Series Cast Iron Sluice Gate as manufactured by Waterman Industries of Exeter, California. Proposed alternates must be pre-approved, per addendum, at least 14-days prior to close of bid. Requests for alternates must be supplemented with detailed drawings, specifications, and references. Any/all additional costs for engineering structure modifications or other changes associated with utilizing a brand other than Waterman are to be borne by the contractor.
3. To insure quality and consistency, the sluice gates listed in this section shall be manufactured and assembled in a facility owned and operated by the sluice gate manufacturer. Machining, testing and performance verification of the gates shall be in a U.S. facility. The client may verify/view the manufacturing and testing process at the facility. Third-party manufacturers contracted for fabrication and assembly of the sluice gates will not be permitted.

PART 2 EQUIPMENT

2.01 GENERAL

- A. The gates shall be either self-contained with yoke and benchstand operators, or non-self-contained with stem guides and operator, in accordance with the requirements of this specification.
- B. The gates shall be compliant with the latest version of AWWA C560, as described below.
- C. Specific configurations shall be as noted on the gate schedule or as shown on the plans.
- D. Materials: see material selection chart page 20.

WRITTEN SPECIFICATIONS

COMPONENTS	MATERIALS (select from the options listed in each section)
FRAME, YOKE, COVER SLIDE, WALL THIMBLES	Cast Iron ASTM A126 Class B or C Cast Iron with 2% Nickel Ductile Cast Iron ASTM A536 Ni-Resist Cast Iron ASTM A436 Type 2 or 2B
YOKES	Cast Iron ASTM 126 Class B Cast Iron with 2% Nickel Ductile Cast Iron ASTM A536 Ni-Resist Cast Iron ASTM A436 Type 2 or 2B Steel ASTM A36 Stainless Steel ASTM A240/A276 AISI Type 304L Stainless Steel ASTM A240/A276 AISI Type 316L Stainless Steel ASTM A240/A276 AISI Type 2205
SEATS	Naval Bronze ASTM B21 Alloy 48200 Low-Zinc Bronze ASTM B98 C65100 Stainless Steel ASTM A240 AISI Type 316 Monel ASTM B164
FLUSH BOTTOM SEALS	Neoprene ASTM D2000 BC 615/625 Grade BE 625
WEDGES AND STEM BLOCKS	Low-Zinc Bronze ASTM B98 C65100 Manganese Bronze ASTM B584 Alloy 86500
STEMS	Stainless Steel ASTM A276 AISI Type 304 Stainless Steel ASTM A276 AISI Type 316 Stainless Steel ASTM A276 AISI Type 2205 Stainless Steel ASTM A564 AISI Type 630 Monel ASTM B164
STEM COVER	Clear Butyrate with Mylar Strip Galvanized A53 Steel Aluminum ASTM B210
STEM GUIDES	Cast Iron ASTM 126 Class B Bronze Bushed Cast Iron with 2% Nickel Bronze Bushed Ni-Resist Cast Iron ASTM A436 Type 2 Bronze Bushed Ni-Resist Cast Iron ASTM A436 Type 2B Bronze Bushed Stainless Steel ASTM A240/A276 AISI Type 304L UHMW Bushed Stainless Steel ASTM A240/A276 AISI Type 316L UHMW Bushed Stainless Steel ASTM A240/A276 AISI Type 2205 UHMW Bushed
WALL BRACKETS	Cast Iron ASTM 126 Class B Cast Iron with 2% Nickel Ductile Cast Iron ASTM A536 Ni-Resist Cast Iron ASTM A436 Type 2 or 2B Steel ASTM A36 Stainless Steel ASTM A240 AISI Type 304L Stainless Steel ASTM A240 AISI Type 316L Stainless Steel ASTM A240 AISI Type 2205
PEDESTALS	Cast Iron ASTM 126 Class B Cast Iron with 2% Nickel Ductile Cast Iron ASTM A536 Steel ASTM A36/A53 Stainless Steel ASTM A240/A276 AISI Type 304L Stainless Steel ASTM A240/A276 AISI Type 316L Stainless Steel ASTM A240/A276 AISI Type 2205
FASTENERS AND ANCHOR BOLTS	Stainless Steel ASTM A193 / A194 Stainless Steel ASTM F593 / F594 Type 304 CW Stainless Steel ASTM F593 / F594 Type 316 CW Stainless Steel ASTM F593 and F594
FINISH	Polyamide Epoxy Coal Tar Epoxy NSF/ANSI 61 Compliant Paint

E. GATE SCHEDULE

EQUIPMENT NUMBER	GATE SIZE, INCH ¹	GATE TYPE + MOUNTING ²	OPENING DIRECTION ³	BOTTOM SEATING ⁴	DESIGN HEAD, FEET		OPERATOR TYPE
					SEATING	UNSEATING	

Notes: 1. Clear opening width by height. 2. W = wall mounted, T= Thimble (specify type E, F, or MJ, see page 6) Y = self-contained, F = flatback, SC=square/circular
 3. U = upward, D = downward 4. FB = flush bottom

2.02 FRAME AND GUIDES

- A. The frame and guides shall be cast one-piece construction or may have guides dowelled and bolted to the frame.
- B. Frames shall be of the standard flangeback or extended flange type with round or rectangular opening as indicated on the plans and in the sluice gate schedule.
- C. A machined dovetail groove for the mounting of the seat facings shall be provided on the front face of the frame for all dovetail embedded seats.
- D. The frame shall be provided with cast-on pads which shall be machined, drilled, and tapped for the mounting of the wedge device.
- E. The back of the frame flange shall be machined to a plane and drilled to match the wall thimble, pipe flange, or anchor bolt pattern.
- F. Guide rails shall be of such length as to retain at least one-half of the vertical height of the slide when it is in the fully opened position.
- G. A groove running the full length of the guide shall be accurately machined to receive the slide tongue, with a nominal clearance of 1/16-inch.

2.03 STEM AND STEM GUIDE(S)

- A. The stem shall be solid stainless steel of the specified grade.
- B. Stem threads shall be machine cut 29 degree full Acme or stub Acme type.
- C. Nominal diameter of the stem shall not be less than the crest of the threaded portion.
- D. Stem guides and brackets shall be cast iron or fabricated stainless steel, with bronze or UHMW bushings.
- E. Two-piece guides shall be adjustable in two directions and shall be so constructed that, when properly spaced, they will hold the stem in alignment and still allow enough play to permit operation per AWWA C560.
- F. Stem guide spacing shall be as recommended by the gate manufacturer for the specific stem size, but in no case shall the unsupported stem length/radius of gyration (l/r) exceed 200.
- G. Stem guide brackets shall be secured to the wall by anchor bolts of sufficient strength and arrangement to prevent unacceptable stem guide deflection due to either axial and/or radial stem loading caused by gate operation forces during manual operation, or caused by motor-operator locked rotor stall conditions.

2.04 COVER (SLIDE)

- A. The cover shall be designed for the design head indicated with a minimum safety factor of 5 with regard to ultimate tensile, compressive and shear strength.
- B. The cover shall be of one piece cast construction with vertical and horizontal ribs, a reinforced pocket to receive the thrust nut, pads to receive the wedges, and a reinforced periphery around the back side of the cover for machining of the dovetail grooves in which the seating faces shall be mounted.
- C. All wedge pads shall be machined, drilled and tapped to receive the wedge devices.
- D. The cover shall have fully machined tongues running the full length of each side to properly engage the guide grooves.
- E. A thrust nut shall be provided to attach the slide to the stem. The nut shall be threaded and, in the case of rising stems, provided with keys and/or two set screws locked into indents in the stem to prevent rotation of the stem.
- F. For non-rising stems, the stem shall turn freely in the thrust nut, to open and close the slides as the stem is rotated, the nut pocket shall be cast on top of the slide so that the stem does not project into the waterway when the gate is fully opened.

2.05 SEATING FACES

- A. All seating faces for both covers and frames shall be malleable corrosion resistant material (see materials section) of a shape that will fill and permanently lock in the dovetail grooves of the slide and the frame. No other means of attachment will be allowed.
- B. The seats shall be machined to a 63 micro-inch finish, or better.

2.06 WEDGES

- A. All wedges and wedge blocks shall be of solid corrosion resistant material and shall be of sufficient number to provide a practical degree of water tightness per AWWA C560.
- B. All wedge bearing surfaces and contact faces shall be machined to give maximum contact and wedging action.
- C. Wedges shall be fully adjustable, but once set shall not rotate or move from the set position.
- D. All wedge fasteners and adjustment screws shall be corrosion resistant.

2.07 SELF-CONTAINED GATES WITH RISING AND NON-RISING STEMS

- A. When a self-contained gate is specified, a yoke shall be mounted on the machined pads provided on the upper ends of the guides.
- B. The yoke shall have a machined bearing surface for the lift, pedestal, or pedestal mounting plate.
- C. The thrust generated by gate operation shall be contained within the gate assembly.
- D. The yoke shall be designed for the thrust produced at actuator rated torque with a safety factor of 5, based on the ultimate strength of the yoke material used.

2.08 FLUSH BOTTOM SLUICE GATES

- A. When a flush bottom closure is specified, a resilient seal shall be attached to the frame so that it is flush with the gate invert.
- B. The flush bottom seal shall be supported by a cast iron or stainless steel bracket which shall be bolted to machined pads provided on the frame.
- C. The seal shall be held in place by a bronze or stainless steel bar which shall be bolted through the seal to the bracket with stainless steel fasteners.

2.09 WALL THIMBLES AND ANCHOR BOLTS

- A. Wall thimbles shall be provided with all gates except those to be mounted on pipe flanges or those gates to be attached to concrete headwalls with anchor bolts, as shown on the plans.
- B. Each thimble shall be of one-piece cast iron up to gates up to 24 width" (modular for above 24 width") or fabricated stainless steel construction and of the section and depth as specified in the plans and gate schedule.
- C. There shall be an integrally cast, or watertight, water stop around the periphery of the thimble.
- D. The front flange of the thimble shall be machined, drilled and tapped to receive the sluice gate attaching studs. Bolt pattern shall match gate bolt pattern.
- E. After machining, the front flange shall be marked with vertical centerline and the word "top" for correct alignment.
- F. Thimbles shall be provided with grout holes as needed in the invert to permit entrapped air to escape. The holes shall be 1-1/2" in diameter, no more than two feet apart and shall be upstream and downstream of the water stop.
- G. A mastic type gasket shall be provided between the sluice gate and the wall thimble.
- H. Gate anchor bolts shall be corrosion resistant.
- I. Gates mounted directly upon the headwall shall be sealed between the gate back and wall with a non-shrink grout. See manufacturers detailed installation instruction.
- J. Wall thimbles to include "E", "F", Mechanical Joint, and/or Bell configurations, or as specified in the plans.

2.10 MANUALLY-OPERATED LIFTS

- A. Sluice gates shall be operated manually by handwheel or crank-operated pedestal floorstands or benchstands as required.
- B. Each lift shall be provided with a threaded cast bronze lift nut to engage the threaded portion of the stem. The lift nut shall have a machined surface, fitted above and below with thrust ball or rolling element bearings.
- C. Handwheel lifts shall be without gear reduction while crank-operated lifts shall have either a single or double reduction. A maximum effort of 40 lbs. pull (25 lb. pull) on handwheel or crank shall operate the gates under the specified operating head.
- D. The gears, when required, shall be steel with machine-cut teeth. Pinion gears shall be supported by bronze bushings or rolling element bearings.
- E. The lift mechanism shall be totally enclosed within a cast iron housing.
- F. The pedestal shall be structural steel, stainless steel, or cast iron.
- G. The hand crank shall be of aluminum and shall be removable. The hand crank shall be a maximum of 15" long.
- H. All lifts for rising stems shall be provided with a galvanized steel stem cover, a tubular aluminum stem cover, or a transparent plastic stem cover with mylar strip position indicator. A dial-type position indicator shall be optional.
- I. Non-rising stem gates shall be provided with a dial-type position indicator unless extension stems, valve boxes, or T-handle wrenches make an indicator impractical.
- J. Handwheels and crank input shafts shall be approximately 36" from the operating floor unless otherwise shown or specified.
- K. The word "open" shall be cast onto the handcrank or handwheel indicating direction of rotation to open the gate.

2.11 PAINTING

- A. All cast iron parts of the sluice gate (not bearing or sliding contact) and stem guides shall be painted in accordance with the section on painting found elsewhere in these specifications. That portion of the wall thimbles which will be in contact with concrete shall not be painted.

2.12 SHOP TESTING

- A. The completely assembled gate and hoist shall be separately shop-operated to insure proper assembly and operation.
- B. The gate shall be adjusted so that a .002" thick gauge (1/2 that required by AWWA standards) will not be admitted at any point between frame and cover seating surfaces.
- C. All gates and equipment shall be inspected and approved by a qualified shop inspector prior to shipment.

PART 3 EXECUTION

3.01 INSTALLATION

- A. Installation of the gates shall be performed in accordance with standard industry practices. It shall be the responsibility of the CONTRACTOR to handle, store, and install the equipment specified in this Section in strict accordance with the Manufacturer's recommendations.
- B. The CONTRACTOR shall review the installation drawings and installation instructions prior to installing the gates.
- C. The gate frames shall be installed in a true vertical plane, square and plumb, with no twist, convergence, or divergence between the vertical legs of the guide frame.
- D. The CONTRACTOR shall fill any void between the guide frames and the structure with non-shrink grout as shown on the installation drawing and in accordance with the grout manufacturer's recommendations.

3.02 FIELD TESTING

- A. After installation, all gates will be field tested in the presence of the ENGINEER and OWNER to ensure that all items of equipment are in full compliance with this Section. Each gate assembly shall be water tested by the CONTRACTOR at the discretion of the ENGINEER and OWNER, to confirm that leakage does not exceed the specified allowed leakage per AWWA C560.



Waterman Industries LLC - Engineered Water Control Products Since 1912
25500 Road 204 Exeter, California 93221 USA Tel: 1-(559) 562-4000 Fax: 1-(559) 562-2277
www.WatermanUSA.com Design and Specification Support: (800) 445-8457