

F-25 MEDIUM DUTY DRAINAGE GATE

- CAST IRON CONSTRUCTION
- AUTOMATIC OPERATION
- FULLY ADJUSTABLE HINGE LINKS
- 25 FOOT SEATING HEAD MAXIMUM

The Waterman Model F-25 Drainage Gate features a high strength, fully adjustable linkage, providing for sensitive adjustment of the flap cover after installation. The design of this gate prevents jamming and assures proper seating through the use of built-in safety stops and a 2½° to 5° seating angle.

Flatback and Spigotback models are available.

A choice of seat facings is available and includes machined or ground iron, bronze or neoprene cover gasket which is available with either iron or bronze mating frame seats.

The use of the Waterman neoprene cover seal provides a long life tight seal, which can be easily renewed. The heavy seal also provides a moderate cushioning of shock loads where some slamming may occur.

This model is **not** recommended for pump discharges where violent slamming can occur.

- Cast Iron Frame and Cover
- High Strength Ductile Iron or Steel Links
- Stainless Steel Studs, Bolts and Pins, Standard. Brass or Monel, Optional.
- Bronze Bushings, Standard. Permanently Lubricated Bronze or Teflon, Optional.
- Minimum 2½° Seating Angle. 24" Diameter and over.
- Minimum 5° Seating Angle. 21" Diameter and smaller.
- Optional 25 lb. and 125 lb. ANSI Flange Drilling.

CAST IRON SEAT - Standard. Used for moderate conditions where costs must be minimized.

BRASS SEAT - Optional. Used for corrosive conditions where long service is important.

NEOPRENE SEAT (with iron or bronze) - Optional. Replaceable in flap cover. Cushions "slam" on closing and provides tighter seal.



Model F-25f - Flatback
Model F-25sb - Spigotback

PARTS LIST		
No.	Name	Qty.
1	FRAME	1
2	COVER	1
3	PIVOT LUG	2
4	HINGE LINK	2
5	HINGE STUD	4
6	HINGE NUT	12
7	HINGE PIN	4
8	HINGE BUSHING	4
9	WASHER	8
10	SPRING PIN	8
11	SETSCREW	2
12	JAM NUT	2

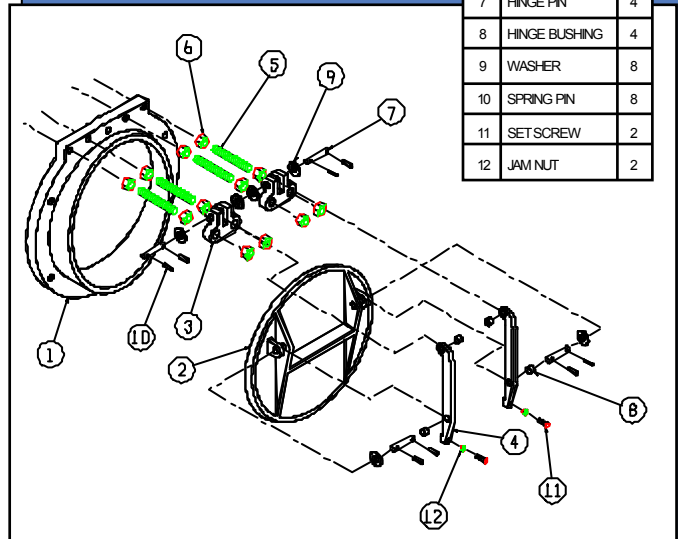

F-25 DRAINAGE GATE

PARTS LIST	
No.	Name
1	FRAME
2	COVER
3	PIVOT LUG
4	HINGE LINK
5	HINGE STUDS & NUTS
6	HINGE PIN
7	HINGE BUSHING
8	WASHERS
9	SPRING PIN
10	SET SCREW 4
11	LUBE FITTING (optional) 6

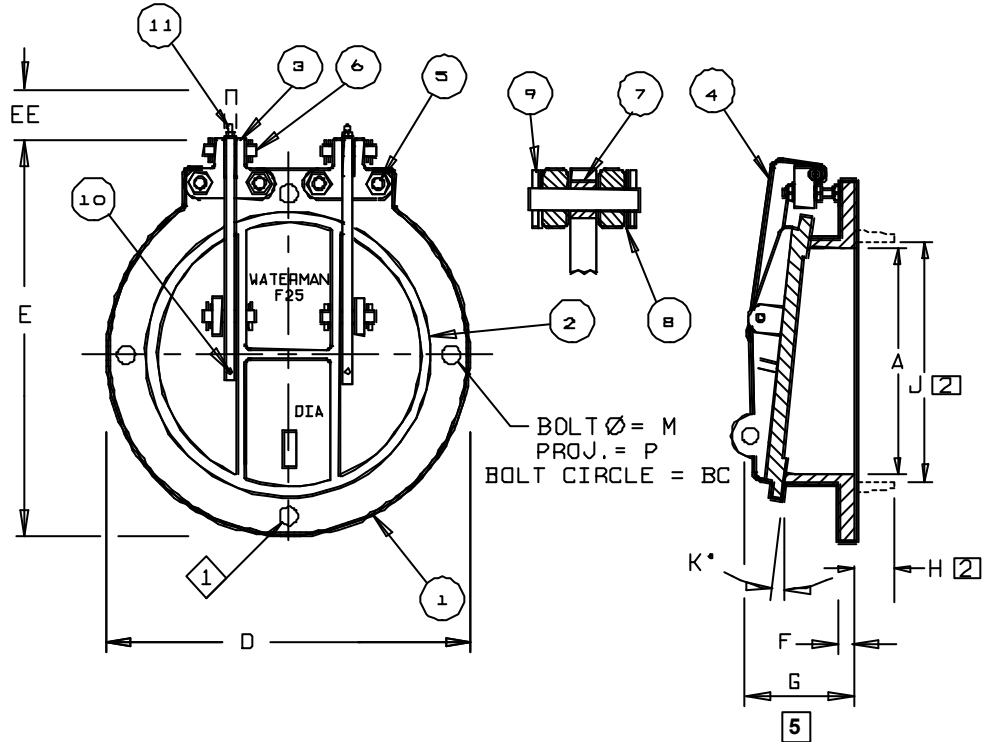

- 1 12 Bolt pattern per available on 42" & 48" only on request.
- 2 Applies to spigotback gate only. Optional spigot shown in phantom.
- 3. 25 Lb. & 125 Lb. Standard drilling available on request for all gates except 15" & 21".
- 4 Except 4" & 6" gates
- 5 If grout pad mounting is used add grout thickness to dimension.
- 6. Not available on 4" and 6" gates - use permlube bushings.

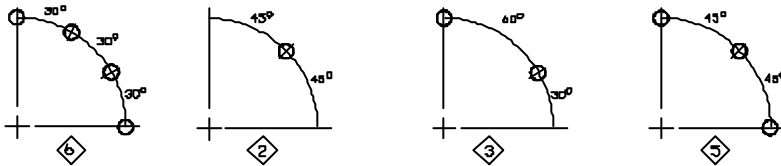
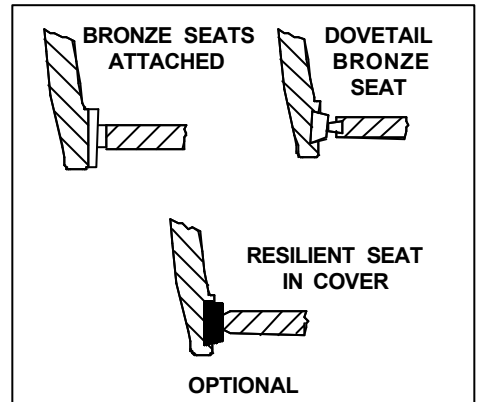

GATE DIMENSIONS IN INCHES

GATE SIZE A	4	6	8	10	12	14	15	16	18	20	21	24	30	36	42	48	54	60
BC	7½	9½	11¾	14¼	17	18¾	20	21¼	22¾	25	25	29½	36	42¾	49½	56	62¾	69¼
D	9	11	13½	16	19	22½	22½	23½	25	27½	27½	32	38¾	46	53	59¾	66½	73
E	9¾	12	14½	16	19	22	25	24	28½	28	30	35	40½	46½	54¾	66	72	75
EE	1⅞	2	2⅞	2⅞	3	3⅞	3⅞	3	3⅞	3⅞	2⅞	3	3½	3½	4⅞	4⅞	6	6⅞
F	½	⅝	⅝	¾	⅝	1	1	⅞	⅞	⅞	⅞	⅞	1⅞	1⅞	1½	1½	1½	1½
G	3⅞	5	5	6	5½	6	6½	6½	7	7	7½	8	8	9	8½	10	10	10 ⅞
H 2	2	2	2⅞	2¼	2⅞	2⅞	2⅞	2¼	2⅞	2⅞	2⅞	2⅞	2⅞	2⅞	2⅞	2½	3	3¼
J 2	5	7	9	11	13	15	16	17	19	21	22	25	31	37	43 ⅞	49⅞	55⅞	61⅞
K*	5	5	5	5	5	5	5	5	5	5	5	2½	2½	2½	2½	2½	2½	2½
M	½	½	½	½	⅝	⅝	⅝	⅝	⅝	¾	¾	¾	¾	¾	⅞	⅞	1	1⅞
P	1½	1½	1½	1½	1½	1½	1½	1½	1½	1¾	1¾	1¾	2¼	2¼	2¼	2¾	2¾	3
No. of Bolts	4	4	4	6	6	6	6	6	6	8	8	6	8	8	6 1	6 1	12	12
	2	1	1	3	3	3	3	3	3	5	5	3	5	5	3	3	6	6

* Degrees

NOTE: FOR PRELIMINARY DESIGN PURPOSES ONLY
DO NOT USE FOR INSTALLATION
UNLESS PART OF CERTIFIED & APPROVED SUBMITTAL



TYPICAL SPECIFICATIONS
F-25 MEDIUM DUTY AUTOMATIC DRAINAGE (FLAP) (TIDE) GATES

General

The drainage gate shall be designed to allow free outflow and prevent backflow for maximum seating heads up to 25 feet. Gates shall be Waterman Model F-25 or equal.

Construction

The frame shall be cast iron of flatback or spigotback design, with machined seating surface inclined from vertical at minimum of $2\frac{1}{2}^{\circ}$, to assure positive closure. For flatback gates mounted to thimbles or flanges, the gate flange shall be machined and drilled to match.

The cover shall be cast iron, cast in one piece, with reinforcing ribs, designed to withstand the seating head specified. An integral cast on lifting eye shall be provided for manual operation.

Seating surfaces for frame and cover shall be:

(bronze on seat and cover) (machined iron on frame, neoprene on cover) (bronze on frame, neoprene on cover)

All machined seats shall have a minimum 63 microinch finish.

The gate shall be provided with adjustable, double pivoted hinge links so designed to permit complete seating, full opening, and with stops or other arrangement to prevent cover from rotating sufficiently to become wedged in the open position. Pivot lugs mounted to frame shall be adjustable to allow adjustment of hinge links without having to remove cover from gate. The hinge links shall be bronze-bushed, structural steel (or high strength ductile iron, cast manganese bronze, or wrought stainless steel). All assembly hardware shall be type 18-8 stainless steel.

Finish

All cast iron shall be painted with manufacturer's standard shopcoat paint (or special paint). Structural steel hinge links shall be galvanized. All bronze and stainless steel parts do not require further finish.

Materials

Frame and Cover - Cast Iron per ASTM A-126, Class B.

Pivot Lug - Ductile Iron per ASTM A-536, Gr. 65-45-12.

Hinge Link - Structural Steel per ASTM A-36, galvanized per ASTM A-123.

Bronze Bushings and Washers - Commercial Bronze.

Assembly Hardware and Pins - 18-8 Stainless Steel (Type 304).