

F-55 FLAP VALVE

SIZES 4" TO 108", HEAVIEST DUTY, RATED UP TO 55 FEET OF SEATING HEAD

STANDARD FEATURES

- **Our highest head model:** seating head of up to 55 feet
- **Positive closing:** minimum of 2½° seat incline.
- **Adjustable, double-pivoted steel hinge links:** permit complete seating, full opening, and prevent cover from rotating sufficiently to become wedged in the open position

SEATING OPTIONS

Standard: Machined iron to machined iron

Optional:

- Bronze to bronze
- Bronze to rubber, with rubber on cover
- Bronze to rubber with rubber on frame

MOUNTING OPTIONS

Standard: Pipe flange mounted (ANSI 125# drilling)

Optional:

- Wall mounted (Waterman drilling)
- Thimble Mounted
- Modified ANSI 125#

FINISH OPTIONS

Standard: Amerlock 400

Optional:

- Specialized paint coatings (including polyamide epoxy paint, Tnemec 69, coal tar epoxy, fusion epoxy - consult with factory for all options) or total galvanizing



ADDITIONAL OPTIONS + UPGRADES

- Leaf spring bumper with rubber cushion block for pump discharge applications, limits cover travel to 90-degrees
- Ni-Resist material for frame, cover and hinge block
- Hinge links in Type 304 or 316 stainless steel
- Hinge bushings: non-metallic, permalube bronze
- Lube fittings for hinges
- Type 316 stainless steel assembly hardware (vs. Type 304)



WATERMAN VALVE LLC

25500 Road 204, Exeter, CA 93221 www.WatermanUSA.com 800.331.0808



F-55 FLAP VALVE

SIZES 4" TO 108", HEAVIEST DUTY, RATED UP TO 55 FEET OF SEATING HEAD

MATERIALS OF CONSTRUCTION

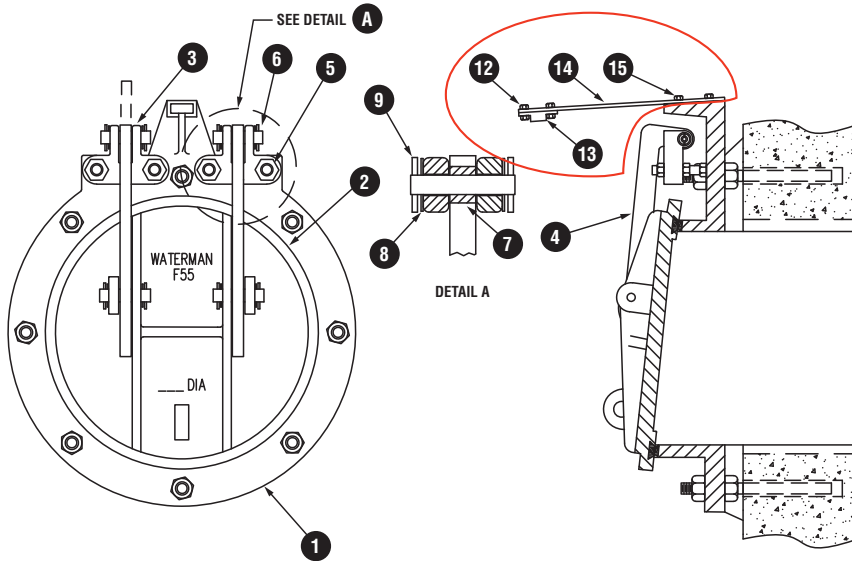

MATERIALS OF CONSTRUCTION		
Number	Name	Material
1	Frame	Cast Iron ASTM A-126, Class B
2	Cover	Cast Iron ASTM A-126, Class B
3	Pivot Lug	Ductile Iron per ASTM A-536, Gr. 65-45-12
4	Hinge Link	Structural Steel per ASTM A-36, galvanized per ASTM A-123
5	Hinge Studs and Nuts	Stainless Steel ASTM F-593
6	Hinge Pin	Stainless Steel ASTM F-593
7	Hinge Bushing	Commercial Bronze
8	Washers	Stainless Steel ASTM F-593
9	Spring Pin	Stainless Steel ASTM F-593
10	Set Screw	Stainless Steel ASTM F-593
11	Lube Fitting (optional, not shown)	
OPTIONAL ITEMS IF SPRING BUMPER IS SPECIFIED		
12	Bumper Bolt & Nut	Stainless Steel ASTM F-593
13	Bumper	Reinforced Rubber
14	Spring	
15	Spring Bolt	Stainless Steel ASTM F-593

F-55 FLAP VALVE

SIZES 4" TO 108", HEAVIEST DUTY, RATED UP TO 55 FEET OF SEATING HEAD

GATE DIMENSIONS (MODELS 4" - 48")

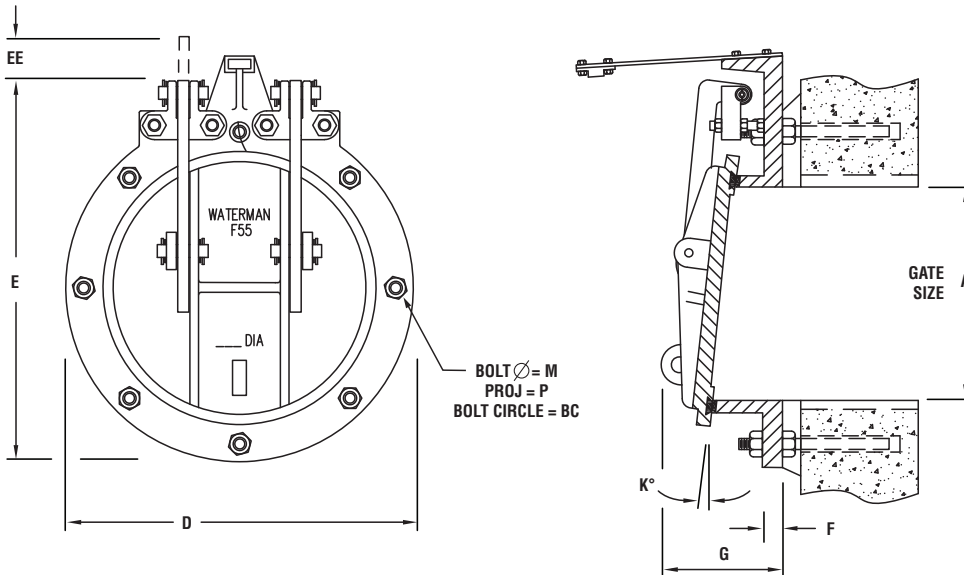

GATE DIMENSIONS IN INCHES

Gate Size A	4	6	8	10	12	14	15	16	18	20	21	24	30	36	42	48
BC	7.5	9.5	11.75	14.25	17	18.75	20	21.25	22.75	25	25	29.5	36	42.75	49.75	56
D	9	11	13.5	16	19	21	22.5	23.5	25	27.5	27.5	32	38.25	46	53	59.75
E	9.75	12	14.5	16	19	22	25	24	28.5	28	30	35	40.5	46.5	54.75	66
EE	1.75	2	2.2	2.6	3	3.2	3.25	3	3.2	3.2	2.8	3	3.5	3.5	4.2	4.8
F	5/8	3/4	3/4	4/5	7/8	7/8	7/8	7/8	1	1	1	1	1 5/8	1 1/8	1.5	1.5
G	3 9/16	2.5	2.75	3	3.5	6	6.5	6.5	7	7	7.5	8	8	9	8.5	10
K	5	5	5	5	5	5	5	5	5	5	5	2.5	2.5	2.5	2.5	2.5
M	5/8	5/8	5/8	5/8	3/4	3/4	3/4	3/4	3/4	3/4	3/4	3/4	7/8	7/8	1	1
P	1.5	1.5	1.5	1.5	1.5	1.5	1.5	1.5	1.5	1.75	1.75	1.75	2.25	2.25	2.25	2 3/8
No. of Bolts	4	4	4	6	6	6	6	6	6	8	8	8	8	8	12	12
BC	2	1	1	3	3	3	3	3	3	4	4	4	4	4	5	5

F-55 FLAP VALVE

SIZES 4" TO 108", HEAVIEST DUTY, RATED UP TO 55 FEET OF SEATING HEAD

GATE DIMENSIONS (MODELS 54" - 108")

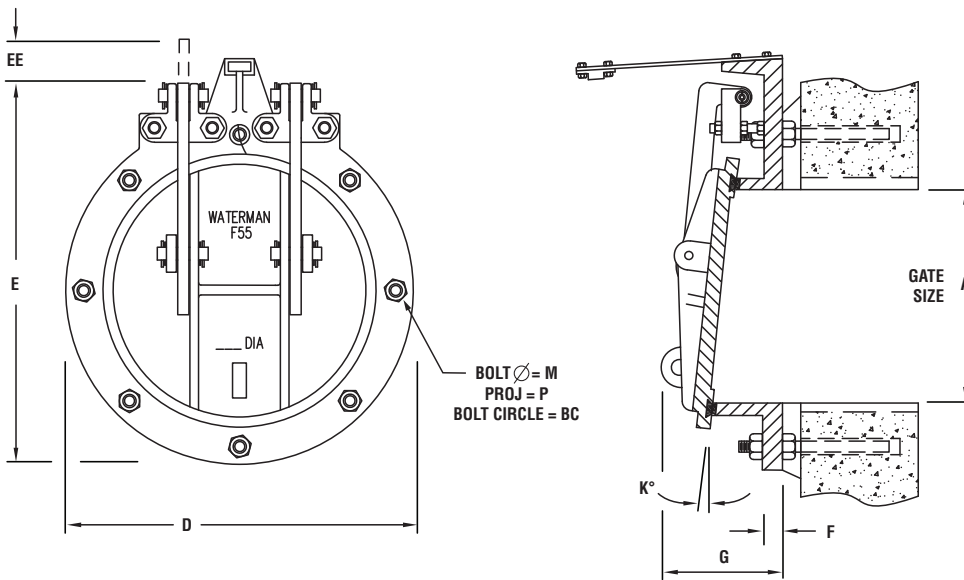

GATE DIMENSIONS IN INCHES

Gate Size A	54	60	66	72	84	96	108
BC	62.25	69.25	76	82.5	95.5	108.5	119.5
D	66.5	73	80	86.5	99.75	113.25	124
E	72	75	85.25	92.25	105.5	119	130
EE	6	6.25	7	10	10	10	10
F	1.75	1.75	2.25	2.25	2.25	2.25	2.5
G	10	10 7/16	14	14.5	17	21	21
K	2.5	2.5	2.5	2.5	2.5	2.5	2.5
M	1	1 1/8	1 1/8	1 1/8	1.25	1.25	1.25
P	2.75	3	3	3.5	4	4.5	4.5
No. of Bolts	12	12	12	16	16	16	24
Q	5	5	5	6	6	6	7