



**MCWANE**  
PLANT & INDUSTRIAL



**KENNEDY VALVE**

# KENFLEX CHECK VALVE

## NO ACCESSORIES

DRAWING NO. - 17054

REV - 01

DRAWN BY - BES

No.	DATE	ECN	REVISION
1	07/20	ER2830	Released to MPI

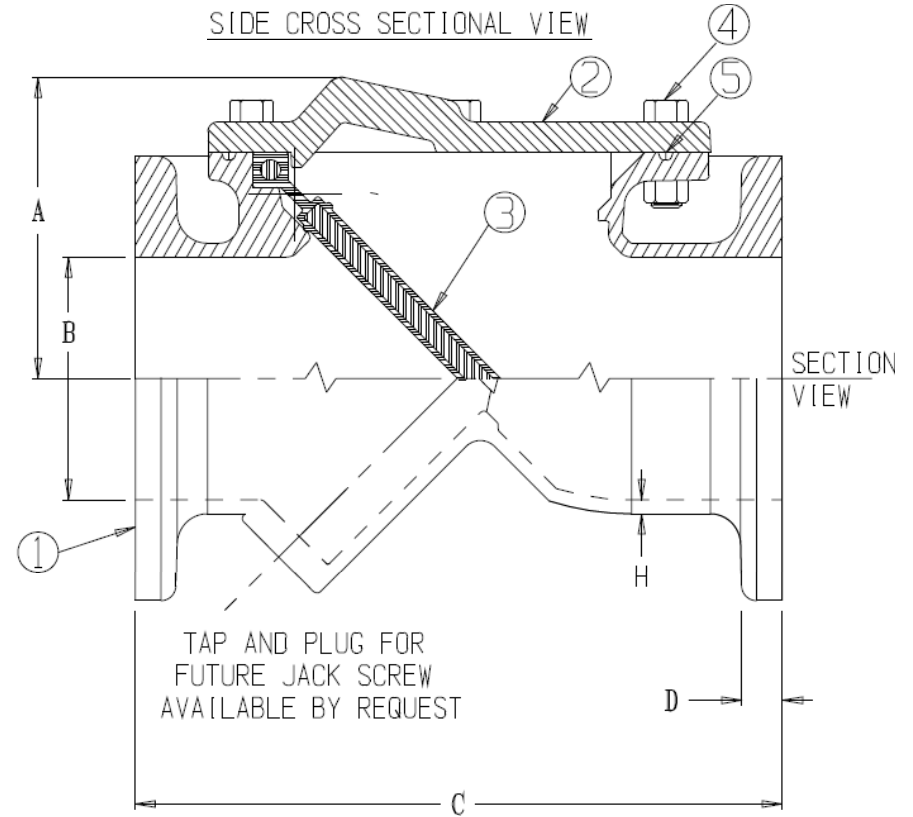
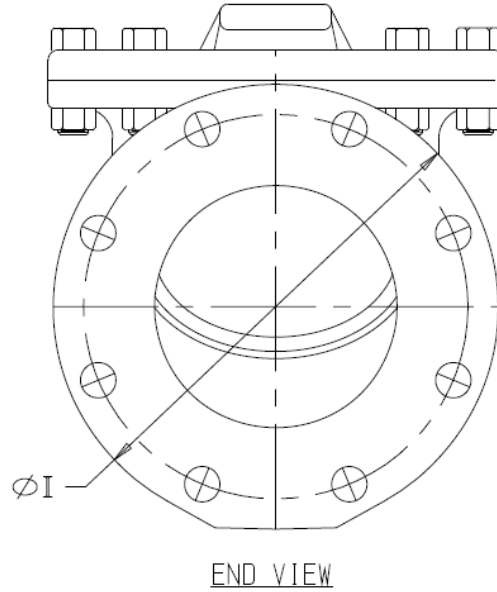

E - BOLT CIRCLE DIA. END FLANGE  
 F - NUMBER OF BOLTS REQ'D EACH END FLANGE  
 G - BOLT HOLE DIAMETER FOR END FLANGE  
 END FLANGES CONFORM TO ANSI B16.1

PARTS LIST			
PART No.	PART	MATERIAL	ASTM DESIGNATION
1	Body (FLG x FLG)	Ductile Iron, Coated	ASTM A536 GR 65-45-12
2	Cover Plate	Ductile Iron, Coated	ASTM A536 GR 65-45-12
3	Flapper	EPDM Flapper, Met. Insert	A536 DI/D-2000 BK 807
4	Cover Bolts & Nuts	Stainless Steel	SS 18-8 F593
5	O-Ring	Nitrile (Buna-N)	ASTM D2000

DIMENSIONS									
SIZE	A (APPROX.)	ØB	C	D (NDM)	ØE	F # BOLTS	ØG	H (NDM)	I
3	5.37	4.00	13	1.00	6.00	4	X	0.31	9.0
4	5.37	4.00	13	1.00	7.50	8	0.75	0.31	9.0
6	7.45	6.00	16	1.06	9.50	8	0.88	0.34	11.0
8	8.77	8.00	19.5	1.19	11.75	8	0.88	0.34	13.5
10	10.20	10.00	24.5	1.25	14.25	12	1.00	0.38	16.0
12	11.61	12.00	27.5	1.28	17.00	12	1.00	0.41	19.0

3" Valve (4) 0.62UNC-11-2B Tapped Holes (G) Straddle C.L. similar to other sizes.