



**MCWANE**  
PLANT & INDUSTRIAL



**KENNEDY VALVE**

# KENFLEX CHECK VALVE WITH POSITION INDICATOR

DRAWING NO. - 17056

REV - 01

DRAWN BY - BES

No.	DATE	ECN	REVISION
1	07/20	ER2830	Released GA Drawing

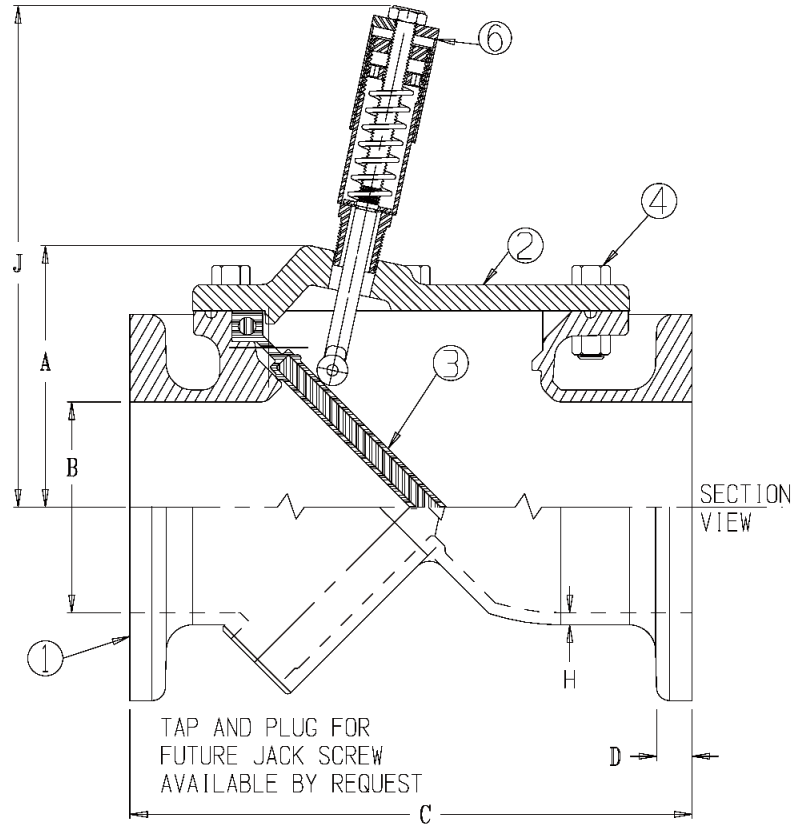

SIDE CROSS SECTIONAL VIEW

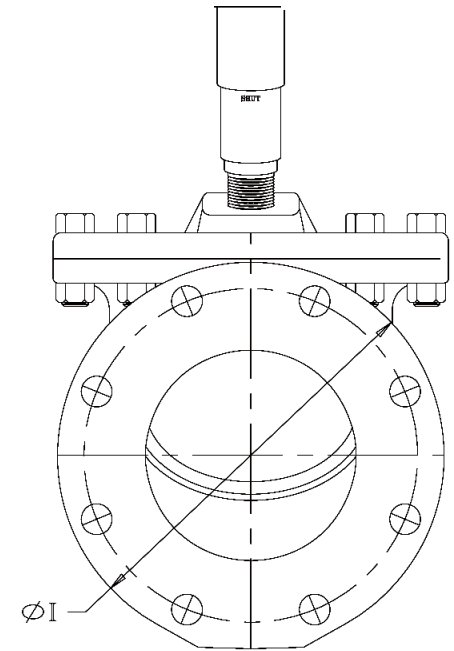

END VIEW

E - BOLT CIRCLE DIA. END FLANGE  
F - NUMBER OF BOLTS REQ'D EACH END FLANGE  
G - BOLT HOLE DIAMETER FOR END FLANGE  
END FLANGES CONFORM TO ANSI B16.1

3" VALVE (4) 0.625UNC-11-2B  
TAPPED HOLES (G) STRADDLE C.L.  
SIMILAR TO OTHER SIZES

## PARTS LIST

PART No.	PART	MATERIAL	ASTM DESIGNATION
1	Body (FLG x FLG)	Ductile Iron, Coated	ASTM A536 GR 65-45-12
2	Cover Plate	Ductile Iron, Coated	ASTM A536 GR 65-45-12
3	Flapper	EPDM Flapper, Met. Insert	A536 DI/D-2000 BK 807
4	Cover Bolts & Nuts	Stainless Steel	SS 18-8 F593
5	O-Ring	Nutrilite (Buna-N)	ASTM D2000
6	Position Indicator Subassembly	Stainless Steel Ext. Components	---

## DIMENSIONS

SIZE	A (APPROX.)	ØB	C	D (NDM)	ØE	F	ØG	H (NDM)	I	J (APPROX.)
3	5.37	4.00	13	1.00	6.00	4	TAP SEE ABOVE	0.31	9.0	12.21
4	5.37	4.00	13	1.00	7.50	8	0.75	0.31	9.0	12.21
6	7.45	6.00	16	1.06	9.50	8	0.88	0.34	11.0	14.28
8	8.77	8.00	19.5	1.19	11.75	8	0.88	0.34	13.5	15.61
10	10.20	10.00	24.5	1.25	14.25	12	1.00	0.38	16.0	17.04
12	11.61	12.00	27.5	1.28	17.00	12	1.00	0.41	19.0	18.45