

RADIAL GATES

USES

- Maintenance of water elevations in canals or spillways
- Increased storage capacity for reservoirs
- Diversion of water for irrigation
- Flow control preserving wide, clear waterways
- Other areas requiring economical water control

Waterman Overflow or Breastwall-type Radial (Tainter) Gates can be engineered for unique applications or can be manufactured from a standardized Waterman design. In either case, they are always made to the customer's exact specifications. They provide a light-weight economical gate that can be opened and closed with a minimum of effort. Waterman Radial Gates can also be ordered for existing locations as replacement gates.



CONSTRUCTION FEATURES

FACE PLATE

The face plate is accurately curved on a required radius to an engineered pivot point. This plate is buttressed along the backside with vertical ribs radiused to match the face plate and stiffened with horizontal support beams along the total width of the plate. The horizontal support beams vary in size with the width of the gate and the maximum head of water. They transfer the pressure from the face plate to the radial arms.

SEALS

Waterman provides two types of seals. For overflow and breastwall-type gates, J-bulb seals are securely attached along both sides of the face plate. This provides a positive seal against the adjustable rubbing plates embedded in the side wall, and on the bottom of the face plate to seal against the invert. For breastwalltype gates with which there is a headwall, an additional flat seal is attached at the top of the faceplate for sealing against the headwall.

Waterman makes available flat, wiper-type rubber seals in place of the J-bulb type. This type of seal is especially useful for existing installations in which there are no side rub plates.



Waterman Valve LLC 25500 Road 204 Exeter, California 93221 USA
Tel: 1-(559) 562-4000 Fax: 1-(559) 562-2277 www.WatermanUSA.com

A McWane Company 

BOTTOM AND SIDE SEALING PLATES

If desired, Waterman can supply stainless steel rubbing plates to provide a smooth contact surface for the side seals throughout the full range of movement of the gate. These plates adjust to permit vertical alignment of the contact surfaces. Stainless steel bottom sill plates can be supplied to provide a smooth level contact surface for the full width of the invert of the gate. This sill plate can be adjusted to permit leveling and alignment with the side plates.

RADIAL ARMS

Acting like columns under an arch, radial arms transfer the pressure from the face plate assembly to the pivot bearings on either side of the gate opening. Fabricated from structural steel shapes, larger and thicker members are used as the gate height increases. The radial arms are accurately punched on the forward or upstream end to match corresponding holes in the horizontal support beams. On the downstream end, a steel pin plate assembly is securely welded to the arm to transmit the force to the pivot pin.

PINS AND PIN BEARINGS

Type 304 stainless steel pivot pins transfer the load to bronze bearings encased in cast iron housings, which are firmly anchored in the concrete structure. The bearings are permanently lubricated or grease lubricated and have sufficient surface area to properly distribute the full load to the structure.

HOISTS

All Waterman Radial Gates are actuated by a single drum wire rope hoist system. The single drum system winds the two operating wire ropes or cables simultaneously. For powering the cable drum, Waterman has available either manual operators or electric operators. Both operators work through a worm/worm wheel type, self-locking gearbox. The electric operator option includes an auxiliary manual handwheel.

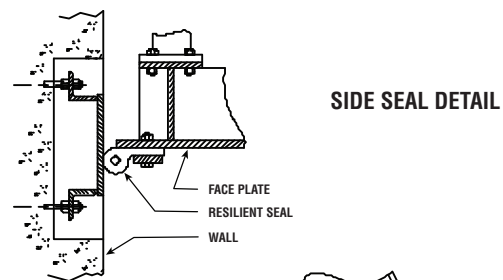
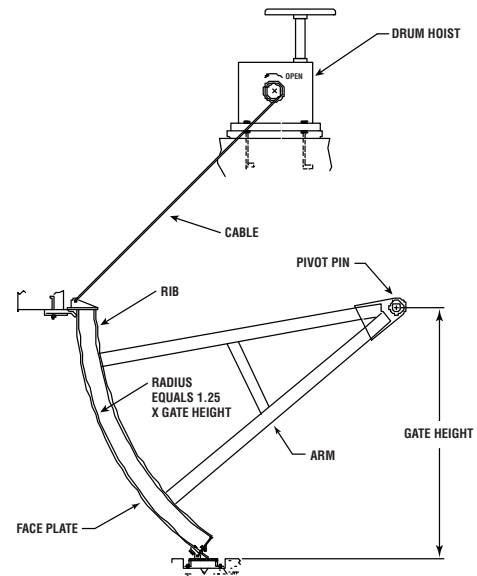

SIDE SEAL DETAIL

BOTTOM SEAL DETAIL

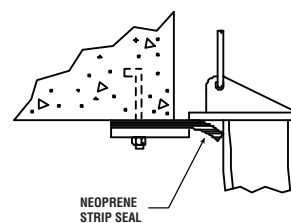
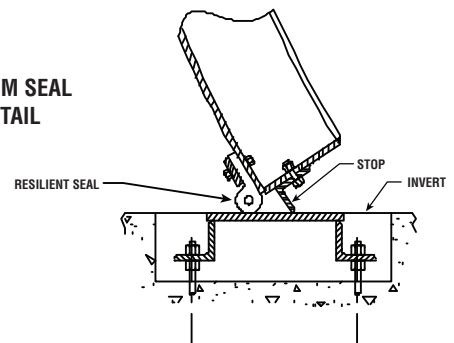

TOP SEAL DETAIL (BREASTWALL TYPE)

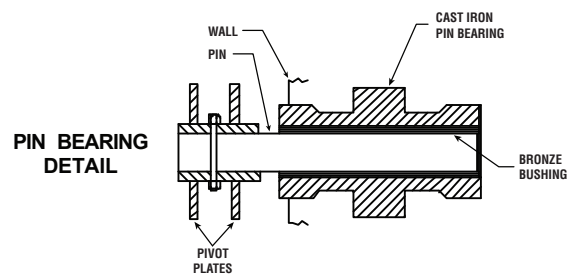

PIN BEARING DETAIL

SPECIFICATIONS

1.01 SCOPE OF WORK

A. The equipment provided under this section shall be fabricated, assembled, erected, and placed in proper operating condition in full conformity with the drawings, specifications, engineering data, instructions, and recommendations of the equipment manufacturer unless exceptions are noted by the engineer.

Gates and operators shall be supplied with all the necessary parts and accessories indicated on the drawings, specified or otherwise required for a complete and properly operating installation, and shall be the latest standard product of a manufacturer regularly engaged in the production of radial gates.

B. Unit Responsibility: To insure compatibility of all components directly related to the radial gates, unit responsibility for the radial gates and accessories as described in this section shall be the responsibility of the radial gate manufacturer unless specified otherwise.

1.02 SUBMITTALS

A. Submittals shall be in accordance with Sections _____ and as specified herein.

Submittals shall include as a minimum:

1. Submittal Drawings.
2. Manufacturer's operation and maintenance manuals and information.
3. Manufacturer's installation certificate.
4. Manufacturer's equipment warranty.
5. Design calculations demonstrating lift loads and deflection in conformance to the application requirements. Design calculations shall be approved by a licensed engineer (PE) and shall be available upon request.

1.03 QUALITY ASSURANCE

A. Qualifications

1. All of the equipment specified under this Section shall be furnished by a single manufacturer with a minimum of 20 years of experience designing and manufacturing fabricated radial gates. The manufacturer shall have manufactured radial gates of the type described herein for a minimum of 20 similar projects.
2. The project design is based on the Waterman Radial Gate as manufactured by Waterman Valve of Exeter, California. Proposed alternates must be pre-approved, per addendum, at least 14-days prior to close of bid. Requests for alternates must be supplemented with detailed drawings, specifications, and references. Any/all additional costs for engineering structure modifications or other changes associated with utilizing a brand other than Waterman are to be borne by the contractor.
3. To insure quality and consistency, the radial gates listed in this section shall be manufactured and assembled in a facility owned and operated by the radial gate manufacturer. Machining and performance verification of the gates shall be in a U.S. facility. The client may verify/view the manufacturing process at the facility. Third-party manufacturers contracted for fabrication and assembly of the radial gates will not be permitted.

PART 2 EQUIPMENT

All cast iron shall be painted with manufacturer's standard shopcoat paint (or special paint). Structural steel hinge arms shall be galvanized. All bronze and stainless steel parts do not require further finish.

2.01 GENERAL

- A. The radial gates and appurtenances shall be in accordance with the requirements of this specification.
- B. Applicable specifications listed below are for the alloy, grade, type or class of material and the condition and finish appropriate to the structural and operational requirements.
- C. Materials:

COMPONENT/MATERIALS	ALLOY/GRADE/TYPE/CLASS
Cast Iron	A48-Class 30 ASTM A126 Class B
Structural Steel Shapes, Plates and Bars	ASTM A36
Carbon Steel Bars	A108, A575 or A311
Stainless Steel	A276 A240 Type 304, 304L 316, 316L
Bronze Bar, Rods and Shapes	ASTM B98 or B21, PermalubeBronze
Steel Assembly Hardware	A307
Stainless Steel Assembly Hardware	ASTM F-593, F-594
Galvanizing	A123 or A153

GATE FACE ASSEMBLY

- A. The face assembly shall consist of horizontal structural members, vertical stiffeners and a curved face plate. Horizontal structural members shall be of adequate size and so located to transmit the thrust from the face of the gate to the radial arms. Design loads placed on the structural reinforcing channels shall not induce stresses in excess of those specified in Section 1.51.4 of AIS Specification for Structural Steel Builders. Minimum ¼ in thick, curved face plate shall be attached to the structural by welding. Sufficient holes shall be located around the perimeter of the assembly for attaching the seals.
- B. Each gate shall be fitted with rubber seals retained by stainless steel bars, along the side and bottom edges of the gate face. The seals shall be of the belt type or "J" type, as specified, and shall be designed to bear on the walls and bottom of the structure or on rubbing plates and sills to insure a water-tight fit when the gate is close. On breastwall gates, a rubber seal shall also be provided at the top edge of the gate.

2.03 RADIAL ARMS

- A. The radial arm assemblies shall consist of structural members welded to a pin plate and drilled to match gusset plates welded to the structural members of the face assembly. The slenderness ratio of the radial arms shall not exceed 150. Bolts for field assembly shall be provided.
- B. A steel pin plate shall transmit the load from the radial arms to the pivot pin collar which shall be welded to the pin plate to distribute the bearing load on the pin. The collar shall be matched drilled with the pivot pin.

2.04 PINS AND PIN BEARINGS

- A. The stainless steel pivot pins shall be sized to transmit the load to the pin bearings. They shall be bolted to the pin plate collar for field assembly.
- B. Permanently lubricated (grease lubricated) bronze bearings encased in cast iron / steel housings shall extend into the concrete and have sufficient surface area to properly distribute the full load to the structure. The bearings shall be bored full length for a running fit with the pivot pin.

2.05 SIDE SEAL RUBBING PLATES

- A. A stainless steel rubbing plate shall provide a smooth contact surface for the side seals throughout the full range of movement of the gate. The rubbing plates shall be adjustable on the anchor bolts to permit vertical alignment of the contact surfaces. Plates shall extend to top of wall or minimum on gate height above the gate top in the closed position. Rubbing plates shall be ¼ inch by 6 inch minimum size.

2.06 BOTTOM SILL PLATE

- A. A stainless steel bottom sill plate shall provide a smooth, level contact surface for the full width of the invert of the gate. The sill plate shall be adjustable on anchor bolts to permit leveling, and alignment with side rubbing plates. Size of bottom sill plates shall be the same as the side rubbing plates.

2.07 WELDING

- A. Manual welding operators performing welding operations on these gates and accessories shall be qualified under the “Standard Qualification Procedure” of the American Welding Society. All welds shall have complete fusion with the base metal and shall be free from cracks, oxides, slag inclusions and gas pockets.

2.08 RADIAL GATE HOISTS

- A. The hoists shall consist of a hoist base, hoist operator, cable drums, drum shafts, cables, and bearing bracket to operate the radial gates. The operators shall be adequate for opening radial gates to double the gate height for operating head specified.

2.09 MANUAL HOIST

- A. The manual hoist operator shall consist of worm and worm gear with, reduction spur gears as required, totally enclosed in cast iron housing. A suitable size handwheel located 36 inches above the operating surface, shall be provided to produce necessary output torque to raise the gate when maximum 40 pound pull is exerted on handwheel rim. The direction of rotation to open gate shall be marked on the handwheel.

2.10 ELECTRIC MOTOR OPERATED HOIST

- A. The electric hoist actuator shall include the motor, operator unit, gearing limit switch, limit switches, torque switches, controls as specified, declutch lever or knob, space heater, gear housings, and auxiliary handwheel as a self-contained unit.
- B. The motor shall be specifically designed for radial gate service and shall be for high torque, totally enclosed, non-ventilated construction, with motor lead brought into the limit switch compartment. Motor insulation shall be NEMA Class B with a maximum continuous temperature rating of 120 Celsius.
- C. The motor shall be of sufficient size to open or close the valve against the maximum expected differential pressure when voltage to the motor terminals is 10 percent above or below minimal 230/460V-3Ph-60Hz voltage. The motor duty rating shall be sufficient for one complete open to close (or reverse) cycle without exceeding its temperature rating. The motor shall be pre-lubricated and all bearings shall be of the anti-friction type.
- D. The actuator power gearing shall consist of generated spur or helical gears of heat treated steel, and worm gearing. The worm shall be of hardened alloy steel and the worm gear shall be of alloy bronze accurately cut with a hobbing machine. All power gearing shall be grease-lubricated. Ball or roller bearings shall be used throughout.

- E. Limit switches and associated gearing shall be an integral part of the actuator. Limit switches shall be of adjustable type capable of being set to trip at any point of gate travel between fully open and fully closed and not be subject to breakage or slippage due to over-travel.
- F. Each actuator shall be equipped with a double torque switch that is responsive to loads encountered in either the opening or closing direction.
- G. The torque switch shall operate during the complete gate cycle without the use of auxiliary relays, linkages, latches, or other devices. The torque switch shall be wired to shut off the actuator motor in the event of excessive torque load applied in either direction of drum rotation or gate travel.
- H. A handwheel shall be provided for manual operation. The handwheel shall not rotate during motor operation nor shall a fused motor prevent manual operation. When in the manual operating position, the unit will remain in this position until the motor is energized at which time the motor operator will automatically return to electric operation and shall remain in the motor powered position/condition until handwheel operation is desired. This movement from motor operation to handwheel operation shall be accomplished by a declutching knob or lever which will disengage the motor and motor gearing mechanically but not electrically. Hand operation must require no more than 40 pounds of rim effort at a maximum required torque. It shall not be possible for the unit to be simultaneously in manual and motor operation. The direction of open for the gate shall be marked on the handwheel.

2.11 FASTENERS

- A. All anchor bolt, assembly bolts, screws, nuts, etc. shall be of ample section to safely withstand the forces created by operation of the gate under the specified pressures and loads. Quantity and size of fasteners shall be as recommended by the manufacturer. Sill anchor/leveling bolts shall be provided with two nuts to facilitate installation.

2.12 FINISH

- A. All structural and other exposed carbon steel surfaces shall be painted or finished as specified. The hoist shall be finished suitable for outdoor exposure.

2.13 SHOP TESTING

- A. All gates and equipment shall be inspected and approved by a qualified shop inspector prior to shipment.

3.01 INSTALLATION

- A. Installation of the gates shall be performed in accordance with standard industry practices. It shall be the responsibility of the CONTRACTOR to handle, store, and install the equipment specified in this Section in strict accordance with the Manufacturer's recommendations.
- B. The CONTRACTOR shall review the installation drawings and installation instructions prior to installing the gates.
- C. The gates shall be installed in a true vertical plane, square and plumb, with no twist, convergence, or divergence in the radial arms or gate face.
- D. The CONTRACTOR shall fill any voids with non-shrink grout as shown on the installation drawing and in accordance with the grout manufacturer's recommendations.

3.02 FIELD TESTING

- A. After installation, all gates will be field tested in the presence of the ENGINEER and OWNER to ensure that all items of equipment are in full compliance with this Section. Each gate assembly shall be tested by the CONTRACTOR at the discretion of the ENGINEER and OWNER, to confirm there is no excessive leakage.



Waterman Valve LLC 25500 Road 204 Exeter, California 93221 USA
Tel: 1-(559) 562-4000 Fax: 1-(559) 562-2277 www.WatermanUSA.com

A McWane Company 

LIT-EP-006 revised May 2018