

# ROLLER GATES

## MODELS AVAILABLE

### MODERATE DUTY ROLLER GATE:

The in-between gate - bridging the gap between slide gate and regular roller gate. Used when a roller gate is desired but the size and loading are not large. Used where gate would have a total hydraulic loading of 10,000 lbs. or less, and up to 30,000 lbs. on other gates depending on height.

Advantages include:

- lower cost
- smaller slot cross-sectional area
- frame can usually be fabricated as rigid single piece weldment. This will ease installation and assure better alignment.

### HEAVY DUTY ROLLER GATE:

For heavy duty service where large loads and sizes are going to be encountered.

Double rail design standard unless otherwise specified. Roller size and slot cross-sectional area increases proportionally to gate size and hydraulic loading.

Larger gates are built in two pieces and shipped separately for field assembly. Due to large size, slot and cross rails also must be bolted together in the field.

### SINGLE RAIL DESIGN AND DOWNWARD OPENING GATES:

Single rail design can also be provided. Less expensive than double rail design with fabricated steel slot, it only requires additional labor to set anchor bolts and assure proper alignment.

Seal mounted on frame is shown in detail at right. This seal arrangement is required on downward opening or skimmer type gates. Shown here with single rail design, it can be supplied just as easily with double rail design.

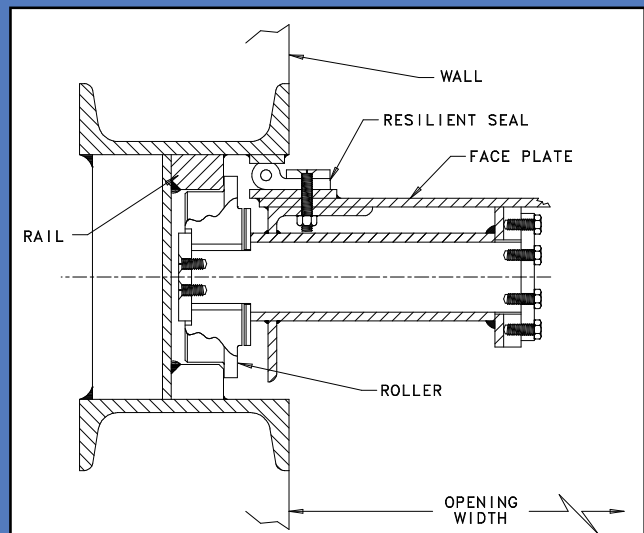

MODERATE DUTY

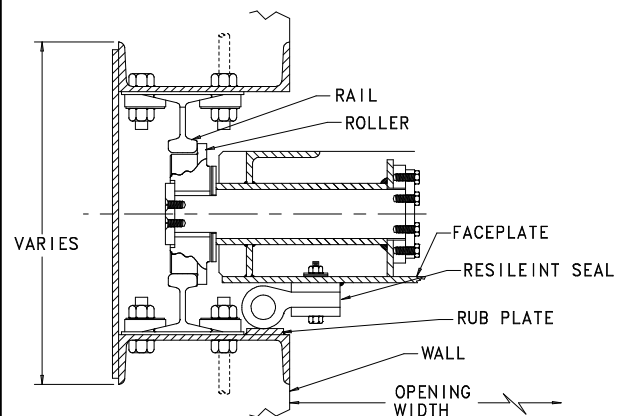

HEAVY DUTY  
DOUBLE RAIL DESIGN

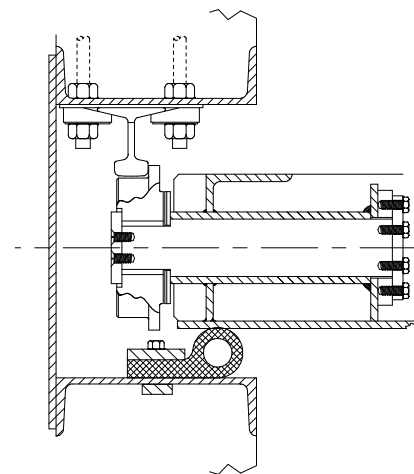

SINGLE RAIL DESIGN