

STAINLESS STEEL SLIDE GATES SS-250 SERIES

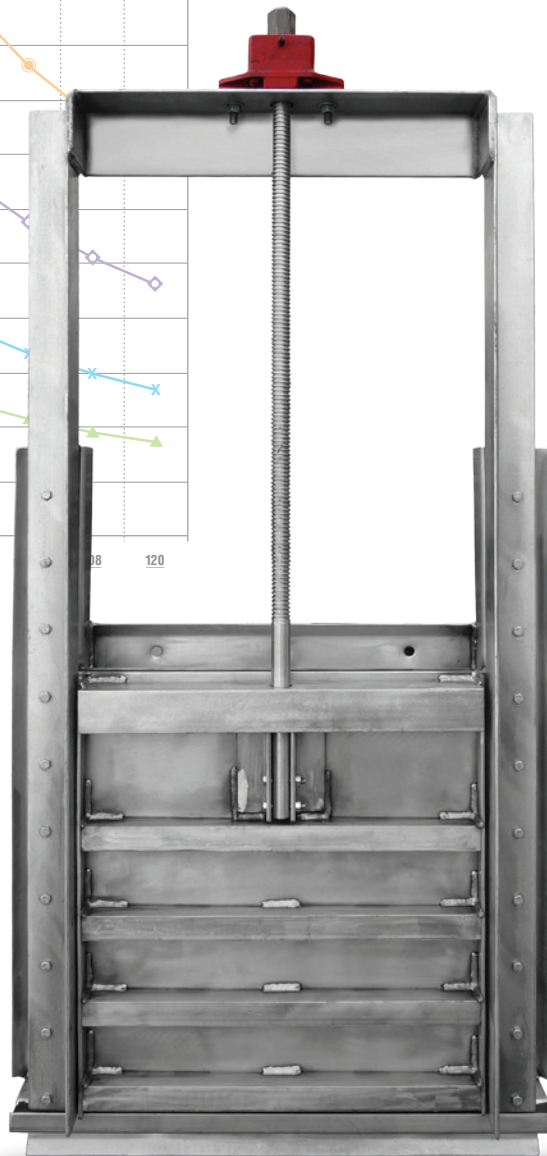

For Generations

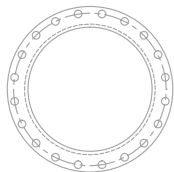
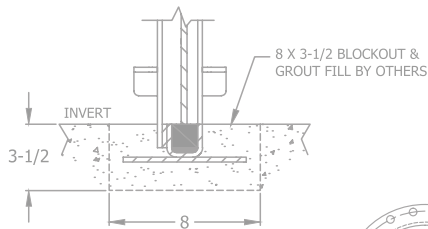
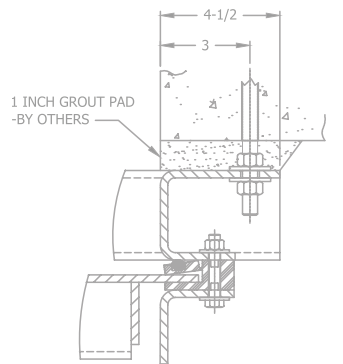
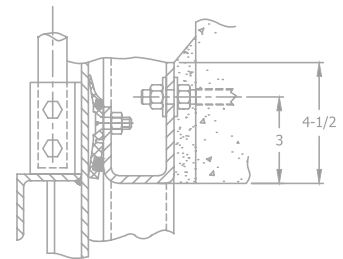
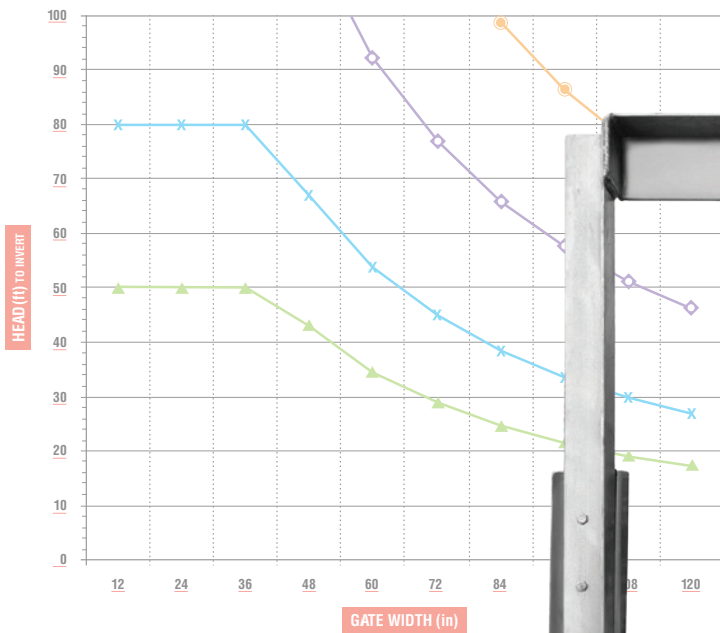

TABLE OF CONTENTS

Overview	3
Configurations Guide	4
Part Number Builder	6
Head Ratings for Custom Sizes, by Series	7
TYPICAL DRAWINGS:	
SS-251-1	8
SS-252-1	9
SS-253-1	10
SS-254-1	11
QSS-256-1	12
SS-257-1	13
Actuator Options – Self Contained Gates	14
Actuator Options – Non-Self Contained Gates.....	16
Non-Rising Stem, Non-Self Contained Gates	18
Gate Mounting Configurations	19
Typical Specifications.....	20-23

For the latest digital copies of all Waterman specifications and drawings,
visit our website at www.WatermanUSA.com

SS-250 SERIES STAINLESS STEEL FABRICATED SLIDE GATES

Company Overview:

The experts at Waterman have custom-engineered thousands of flow control gates for projects worldwide. Waterman's team excels at developing innovative custom solutions to project needs. Our commitment to a highly-trained, customer-focused engineering department is unmatched by our competitors. Using computer modeling technology and finite element analysis, Waterman has systematically improved the design and construction of fabricated gates.

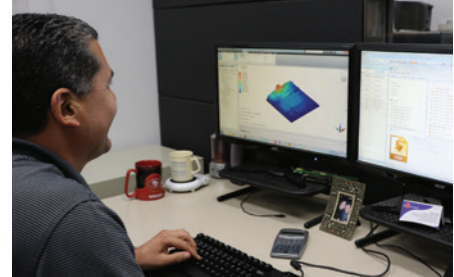

Product Overview:

Best-in-class fabricated water control gates provide reliable performance for water, wastewater and hydropower applications. They are noted for their excellent sealing / leak resistance and for their long service life. Each gate is custom-designed to your project's requirements including seating and unseating heads incorporating safety factors per AWWA standards. SS-250 series gates conform to NSF 61/NSF 372.

Key Advantages and Performance:

- **Built for longevity and corrosion resistance** high strength 304L stainless steel and low-friction UHMW PE sliding and sealing surfaces lengthen the life of the gate. Optional 316L or 2205 stainless steel for use in unusually corrosive environments.
- **Guardian® seal system** (US Patent #8,820,711 awarded August 2015) dramatically increases seal life in both top and flush-bottom seals. Reduces leakage at critical corner joints. Offers superior performance to competitors' UHMW J-seal designs. No metal-to-metal contact prevents gate "sticking" and allows reliable operation even after years of no operation.
- **Best in class leakage performance** Guardian® UHMW PE continually self-adjusting seal system offers leakage rates up to 5 times better than the AWWA C561/C562 specification. The sealing system has been tested for 100,000 cycles (4x leading competitor) and continued to outperform the AWWA leakage specification.



Options:

- Models for normal aperture configuration, channel (embedded or surface mounted) as well as weirs (downward opening, often applied for decant and level control)
- SS-250 can be ordered as self-contained gates or with extension stems and separate operators.
- Gate frames can be embedded in channel walls, mounted to a wall with anchor bolts, mounted to a pipe flange or wall thimble. (Waterman offers a complete line of wall thimbles including “F”, “E”, “spigot style” as well as custom configurations.)
- “Q” seal bottom seal for high debris environments.
- Manual, electric or hydraulic actuation.
- Also available: A-250 Series Aluminum Slide Gates

SS-250 STAINLESS STEEL SLIDE GATE CONFIGURATIONS

TYPE OF GATE (OPENING)	APERTURE		END OF CHANNEL			IN CHANNEL	
	STANDARD	DOWNWARD OPENING	UPWARD OPENING	DOWNWARD OPENING (WEIR)	NON RESTRICTED FLOW	EMBEDDED GUIDE	WALL MTD. GUIDE
RISING STEM	251	252	253	254	255	256	257
MACHINED FLANGE	251-F	252-F					
CIRCULAR FLANGE	251-CF	252-CF					
FULLY CONTAINED SLIDE IN GUIDE RAIL	251-L	252-L	253-L	254-L	255-L	256-L	257-L
SELF-CONTAINED GATE	251-Y	252-Y	253-Y	254-Y	255-Y	256-Y	257-Y
NRS COVER	251-N	252-N	253-N	254-N	255-N	256-N	257-N
SPECIAL OR MODIFIED APPLICATION	251-X	252-X	253-X	254-X	255-X	256-X	257-X



FABRICATED STAINLESS STEEL GATES ADDITIONAL INFORMATION

NSF 61 / NSF 372:

The SS-250 series water control gates (6" – 120") conform to the requirements of NSF/ANSI 61 Drinking Water System Components – Health Effects and NSF/ANSI 372. They conform with the lead content requirements for "lead free" plumbing as defined by California, Vermont, Maryland, and Louisiana state laws and the U.S. Safe Drinking Water Act.

Range of Sizes:

Waterman offers in-stock gates in standard dimensions for quick delivery and lowest total cost. In addition, we can custom design and manufacture gates in a nearly unlimited range of sizes and configurations.

Non-Rising Stem:

Fabricated gates can be ordered with a non-rising stem for areas with restricted space above the gate operator. The disadvantage of a non-rising stem is the threaded operating nut and stem are always exposed in the gate well. Lubrication of the threads becomes difficult to maintain and can lead to premature wear.

Optional Wall Thimbles:

Waterman can supply wall thimbles for mounting of fabricated gates. A thimble can be requested to ship prior to the gate so that it can be included in concrete forms before the structure is poured. Use of a thimble dramatically reduces the time for installation by eliminating labor of placing and aligning anchor bolts and the potential for misplaced or misaligned anchors. With a properly-installed thimble, the gate can be installed quickly when it arrives on site. See page 19 for a complete range of configurations.

Tandem Lifts / Interconnected Actuators:

For large gates, tandem actuators can be specified. This configuration is often used for gates over 72" width.

Actuator Loads for Structures:

For standard gates that are not self-contained, opening and closing thrusts from the actuator are resisted by the structure. Consult with Waterman's engineering department for appropriate design parameters.

Actuators:

Waterman gates can be supplied with manual, electric or hydraulic actuators.

Manual actuators are typically geared "crank type" lifts, although handwheel-type actuators can be applied on small-sized gates with low operating loads. In situations where it will take substantial manual effort / time to open a gate, Waterman can supply electric or gasoline-powered portable operators. Consult with Waterman's engineering department for specifications.

Electric actuators provide convenience for frequent opening, faster opening speeds and readily lend themselves to automation.

Hydraulic cylinders are frequently used in repetitive cycling applications and where automatic gate opening / closing in the event of a power failure is desired.

AWWA Fabricated Slide Gate Part Numbering Guide

PART NUMBER BUILDER

SS-25 1- 1- Y- 36 x 42 10

Material	Opening Configuration Type	Series	Options	Dimensions W x H	Head Rating
A-25 = Aluminum SS-25 = Stainless Steel	1 = Standard 2 = Downward Opening 3 = Upward Opening 4 = Weir 5 = End of Channel Non Restricted Flow 6 = Embedded Guide 7 = Wall Mount	Indicate 1, 1.5, 2, or 3	Indicate F = Flanged CF = Circular Flange Modified ANSI 125# drilling LF = Fully Contained Slide Y = Self Contained Gate N = Non-Rising Stem Cover X = Special or Modified Option Q = Flush Bottom Seal T = Mounted to Wall Thimble	(separate with X), if metric, indicate MM after each number for millimeters	indicate head rating in 5' increment

SS-251-1-Y-36 x 42-10

Indicates a stainless slide gate, standard series, self-contained, with 36" W x 42" H, rated for 10 feet of head.

STAINLESS STEEL GATE SERIES HEAD RATINGS FOR CUSTOM SIZES

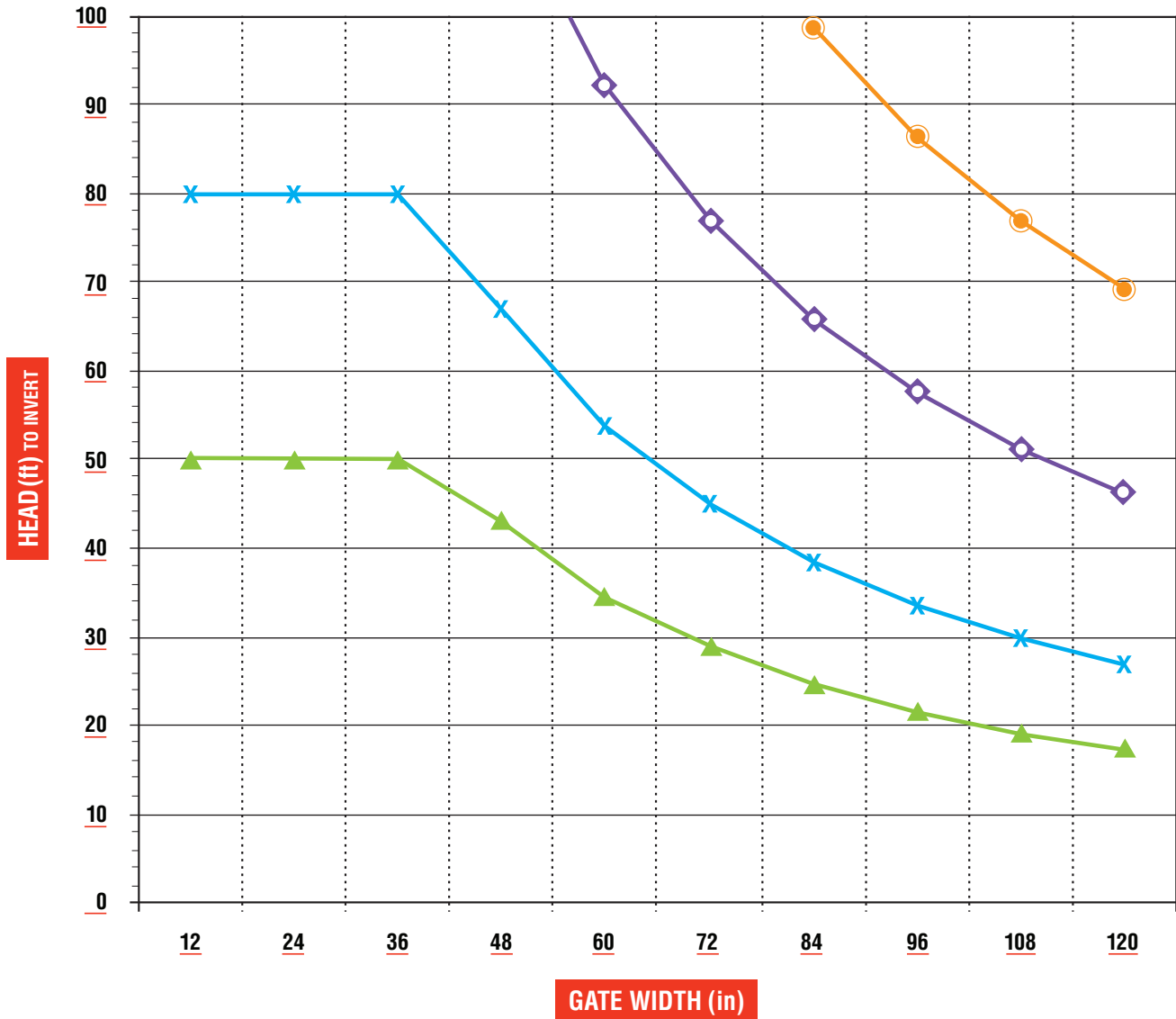

▲ SS-250-1 | × SS-250-1.5 | ◆ SS-250-2 | ● SS-250-3

Drawings shown in this booklet are for 250-1 models only. Request drawings and specs for other models.

NOTES:
 1) Formula to determine seat pressure:
 Gate width (in) * Head (ft) * .2166

SS-251-1 SLIDE GATE

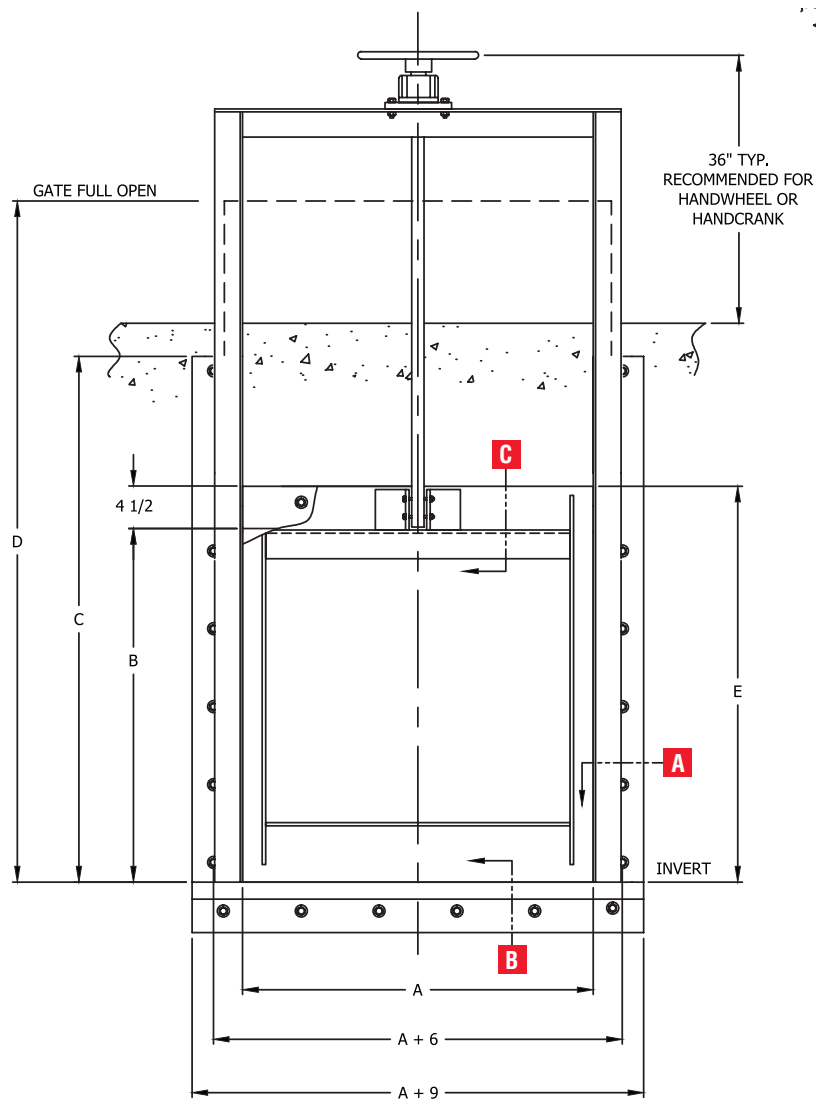

A	Gate Opening Width
B	Gate Opening Height
C	Guide Rail Height = $B + 1/2$ of Slide
D	Gate Full Open = $2B + 4-1/2$
E	Slide Height = $B + 4-1/2$

ALTERNATE "Q" BOTTOM

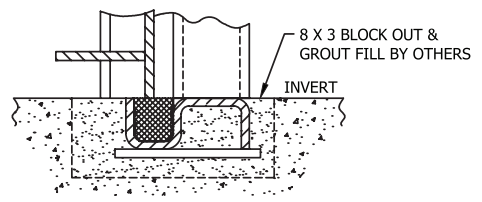

SECTION C

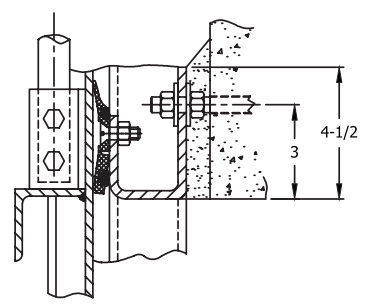

SECTION B

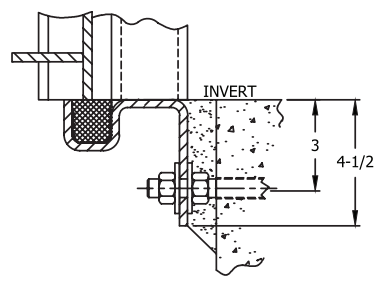

SECTION A

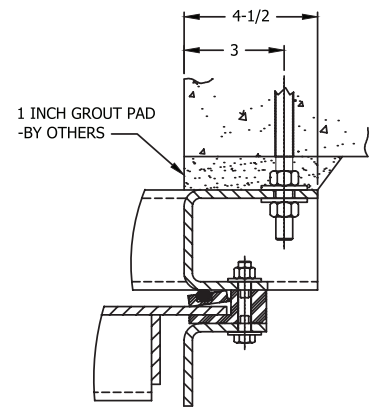

SS-253-1 SLIDE GATE

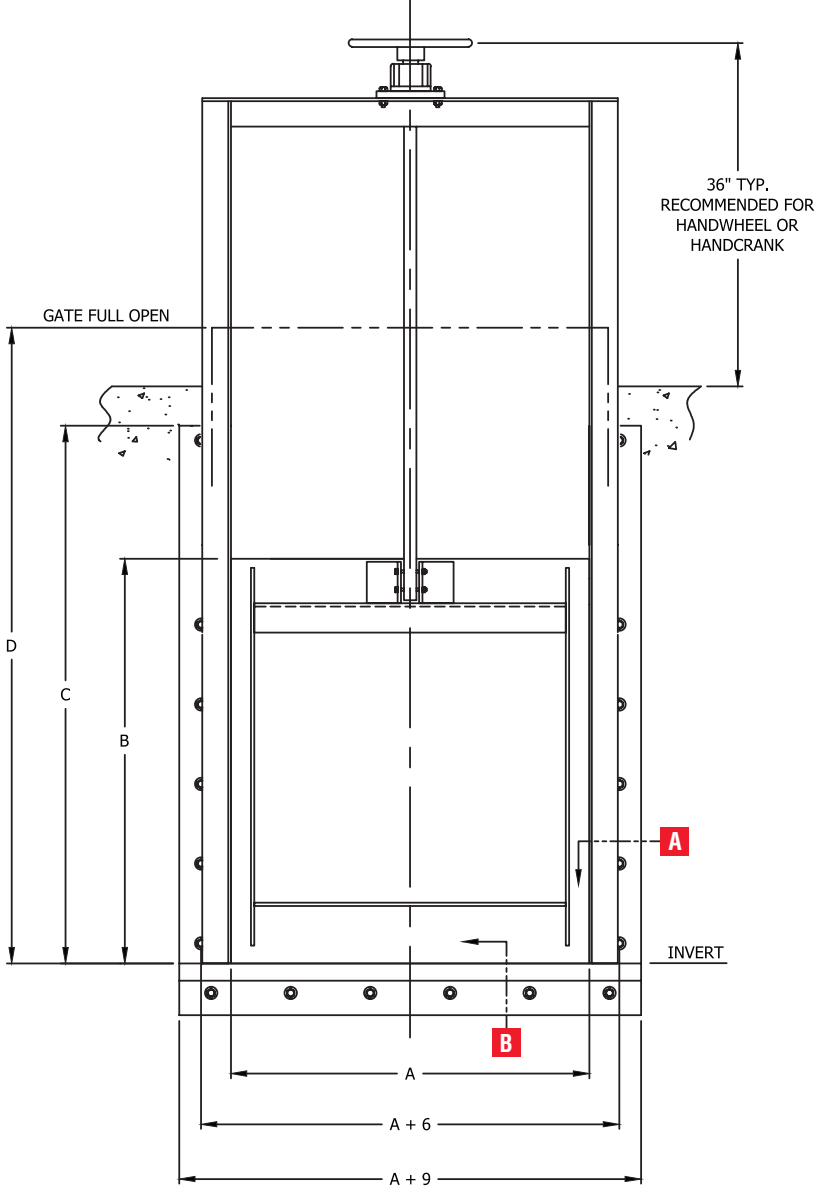

A	Gate Opening Width
B	Gate Opening Height
C	Guide Rail Height = $B + 1/2$ of Slide
D	Gate Full Open = $2B$
E	Slide Height = B

ALTERNATE "Q" BOTTOM

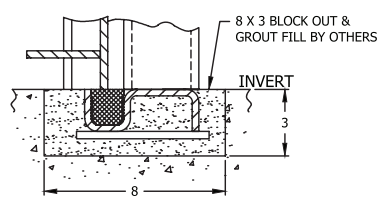

SECTION B

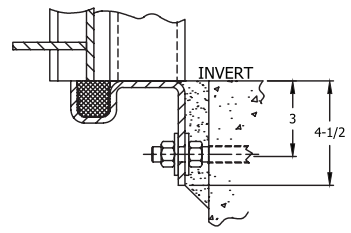

SECTION A

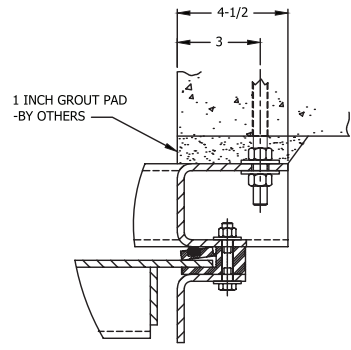

SS-254-1 SLIDE WEIR GATE

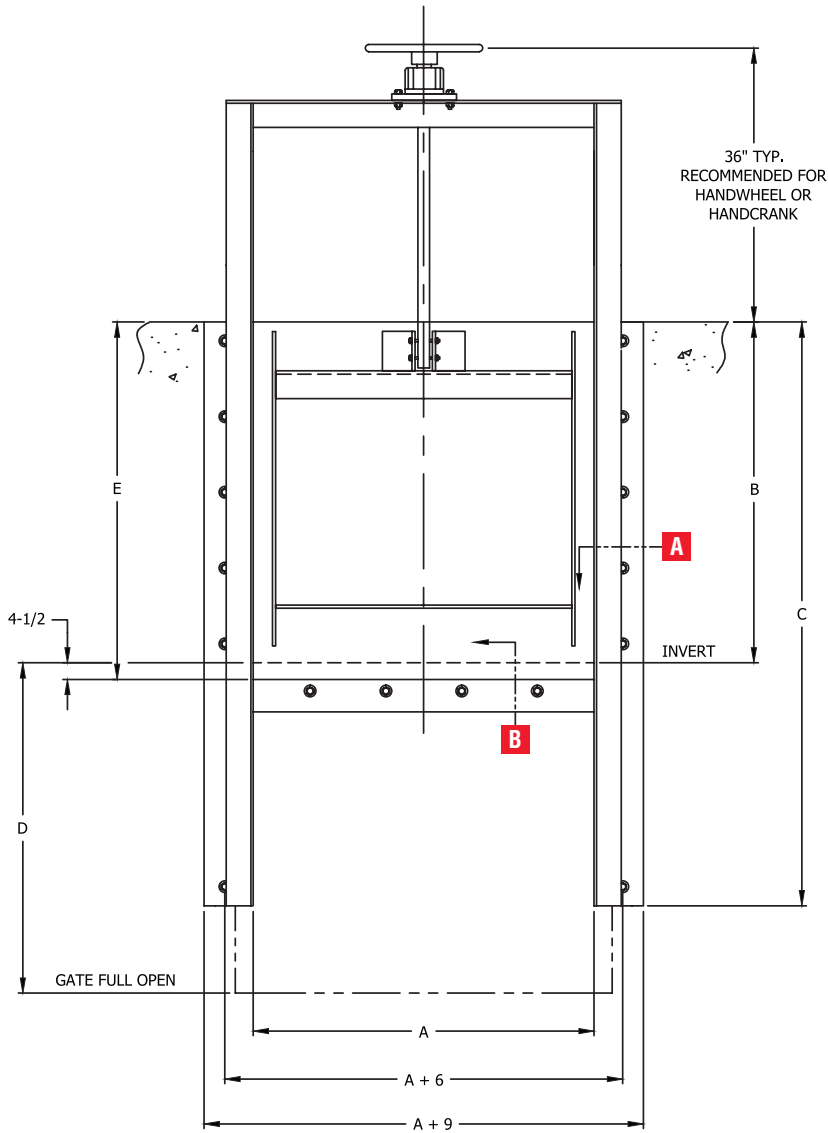

SECTION B

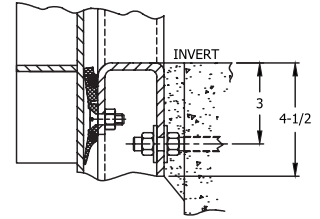

SECTION A

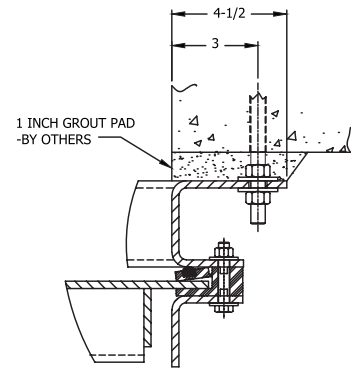

- | |
|---|
| A Gate Opening Width |
| B Gate Opening Height |
| C Guide Rail Height = $B + 1/2$ of Slide |
| D Gate Full Open = $B + 4-1/2$ |
| E Slide Height = $B + 4-1/2$ |

QSS-256-1 SLIDE GATE

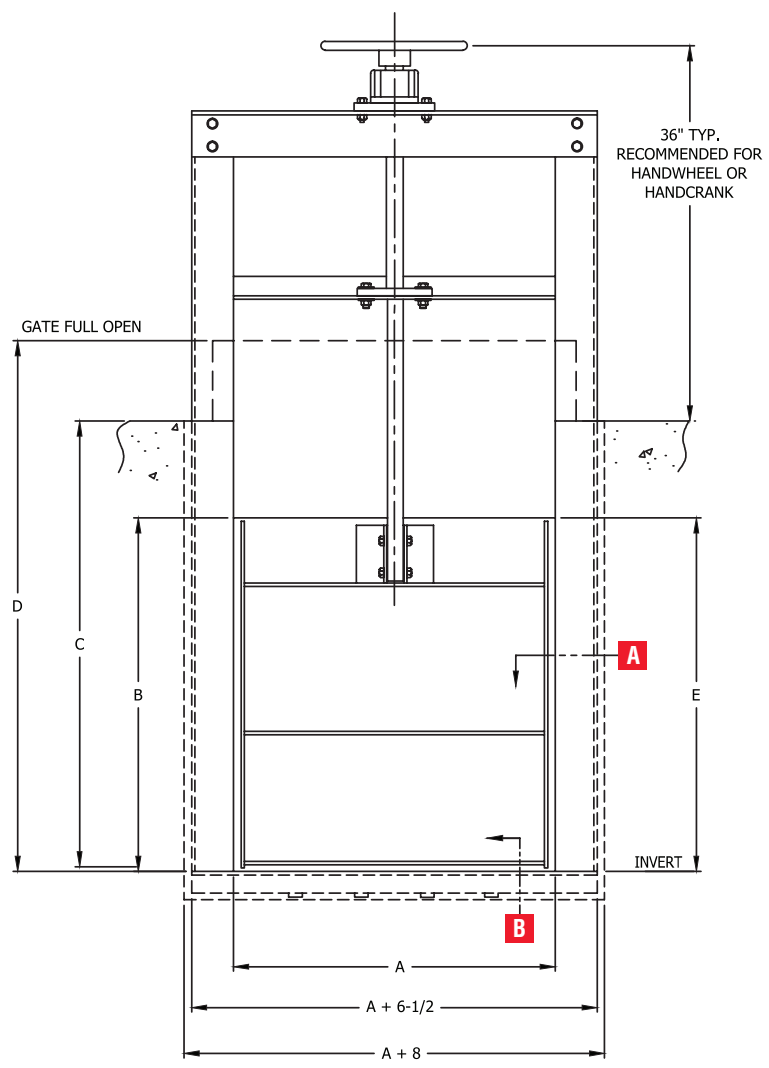

SECTION B

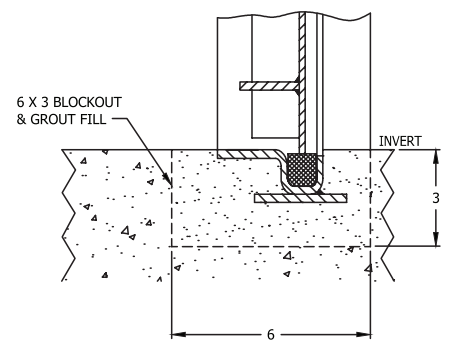

SECTION A

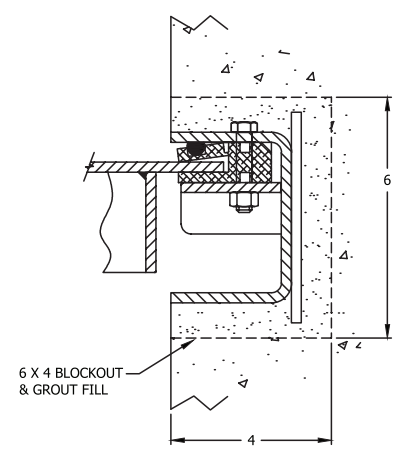

A	Gate Opening Width
B	Gate Opening Height
C	Guide Rail Height = $B + 1/2$ of Slide
D	Gate Full Open = $2B$
E	Slide Height = B

SS-257-1 SLIDE GATE

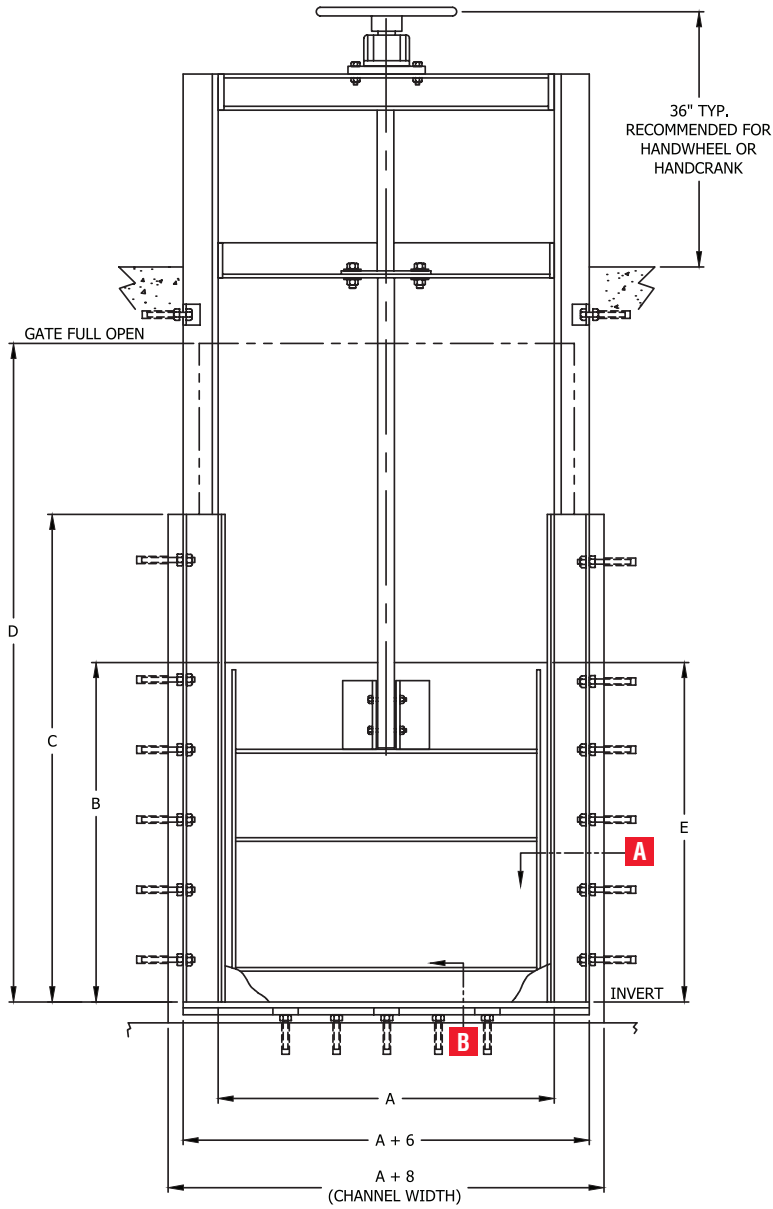

SECTION B

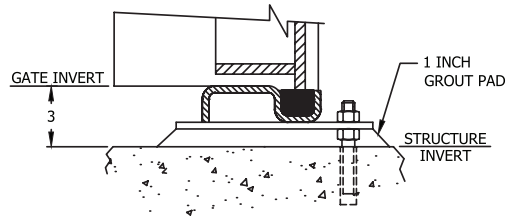

SECTION A

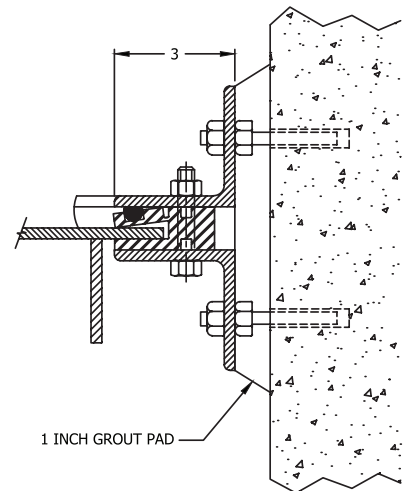

A Gate Opening Width

B Gate Opening Height

D Gate Full Open = 2B

E Slide Height = B

ACTUATORS SELF CONTAINED SLIDE GATES

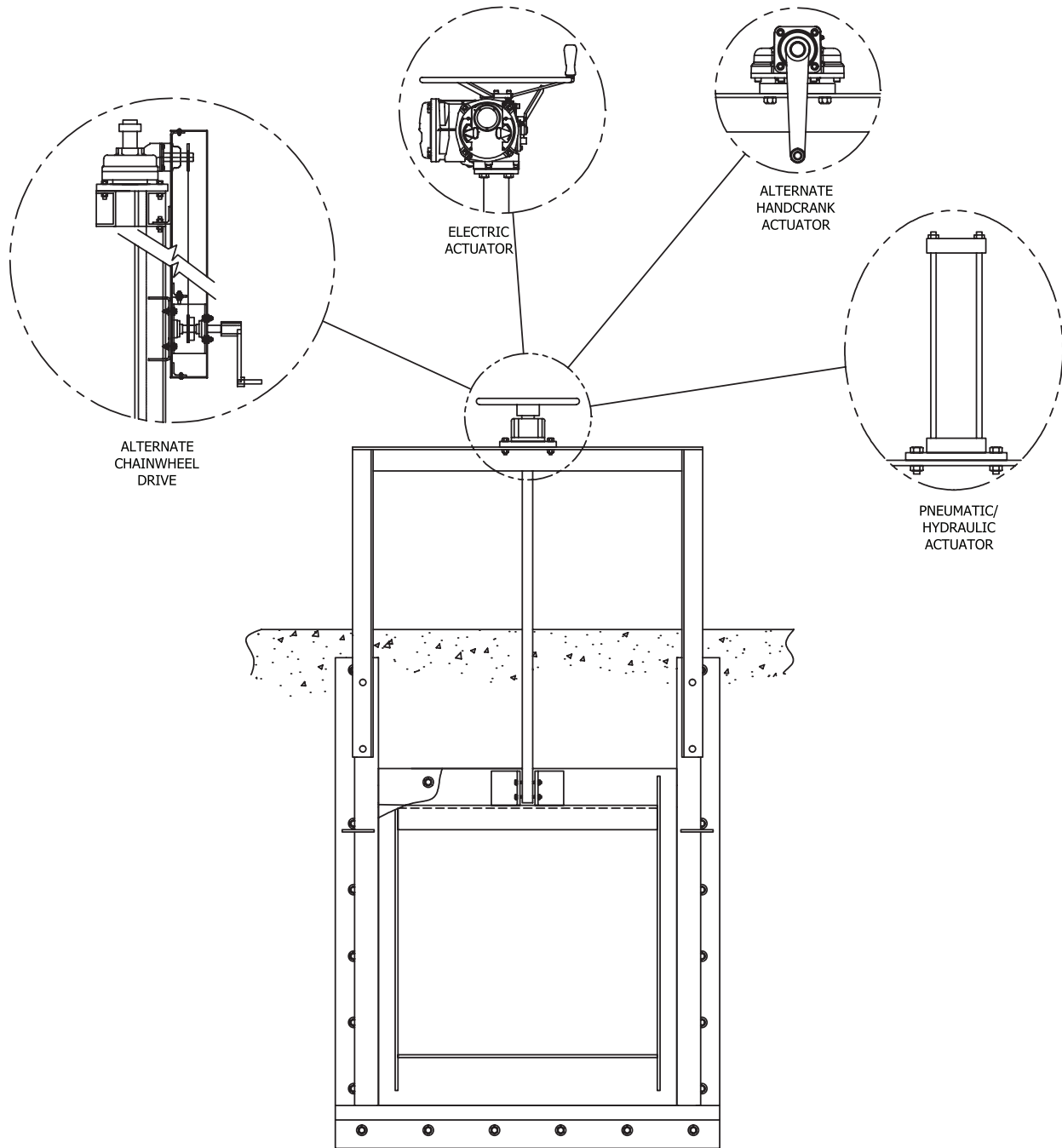

SINGLE LIFT & STEM

ACTUATORS SELF CONTAINED SLIDE GATES

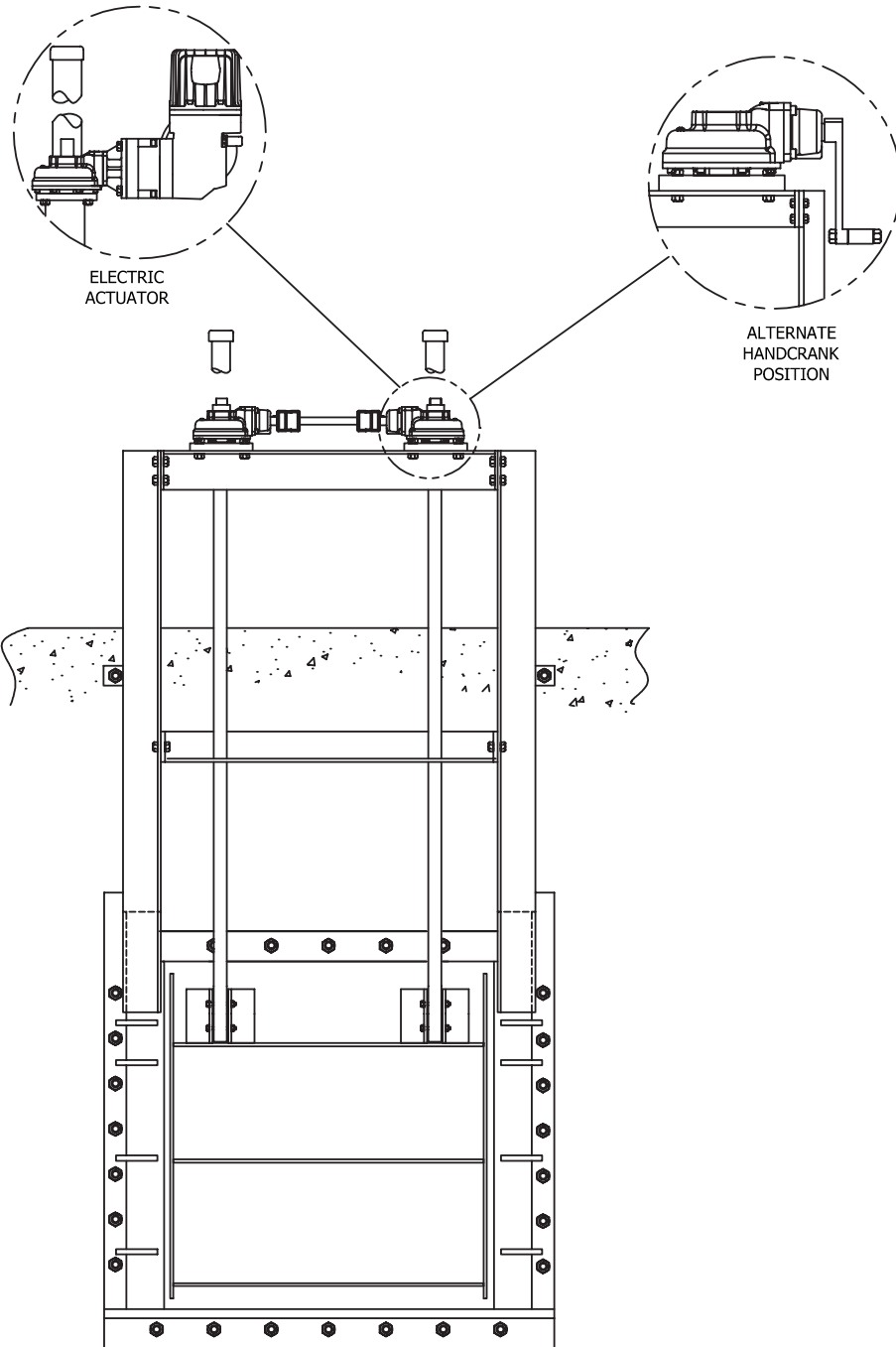

**TANDEM LIFTS
WITH DUAL STEMS**

ACTUATORS NON-SELF CONTAINED SLIDE GATES

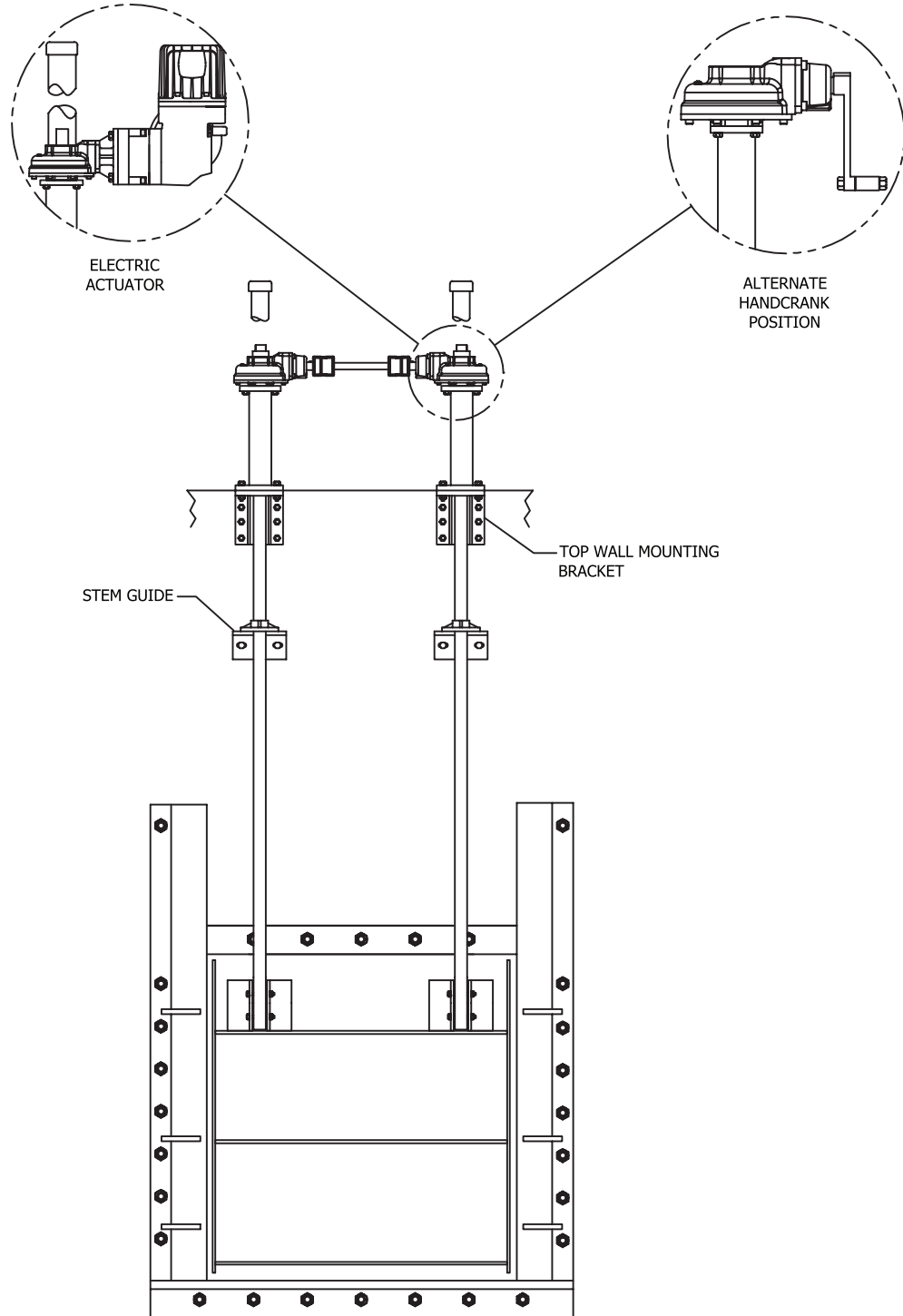

**TANDEM LIFTS
WITH DUAL STEMS**

ACTUATORS NON-SELF CONTAINED SLIDE GATES

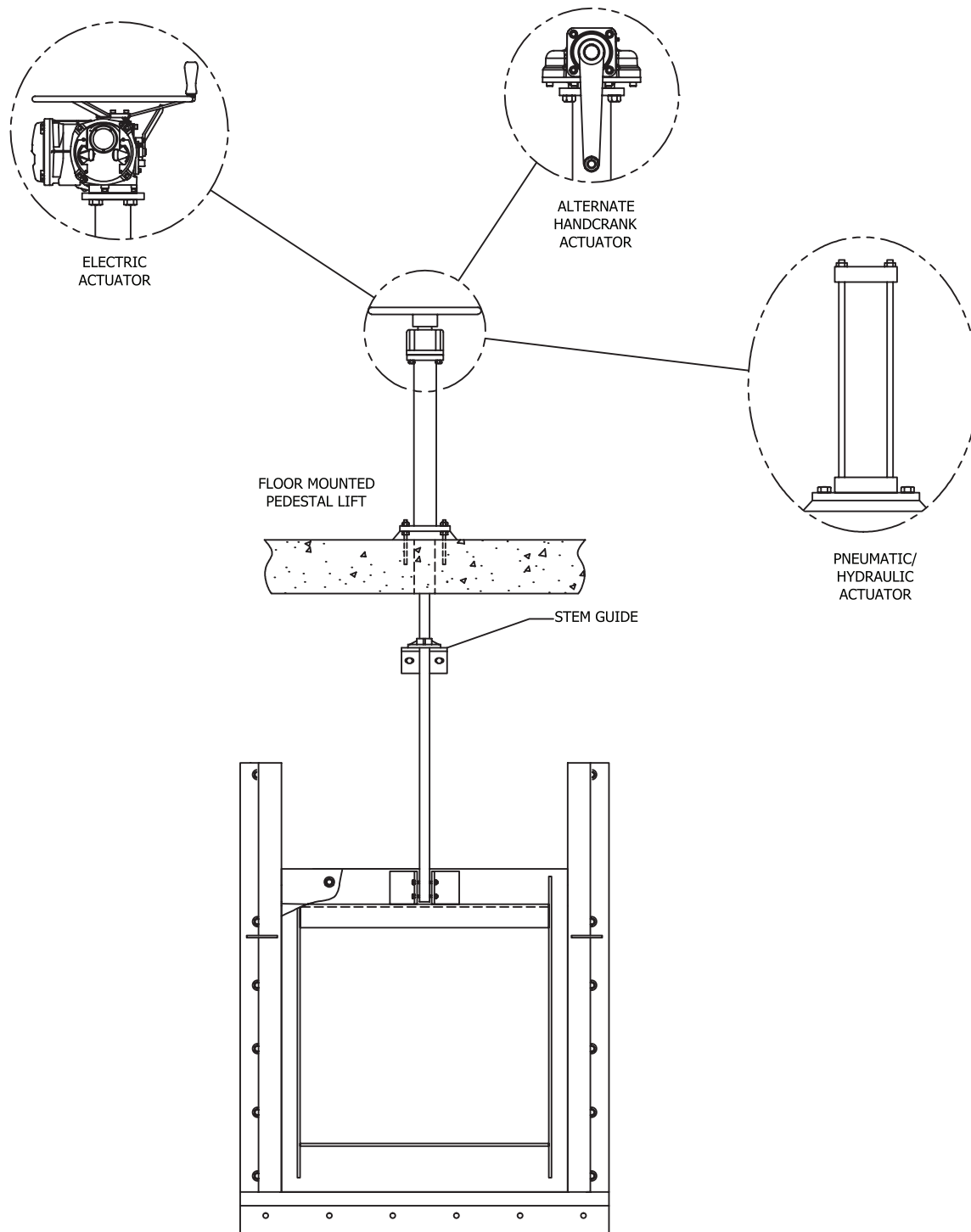

SINGLE LIFT & STEM

NON RISING STEM NON-SELF CONTAINED SLIDE GATES

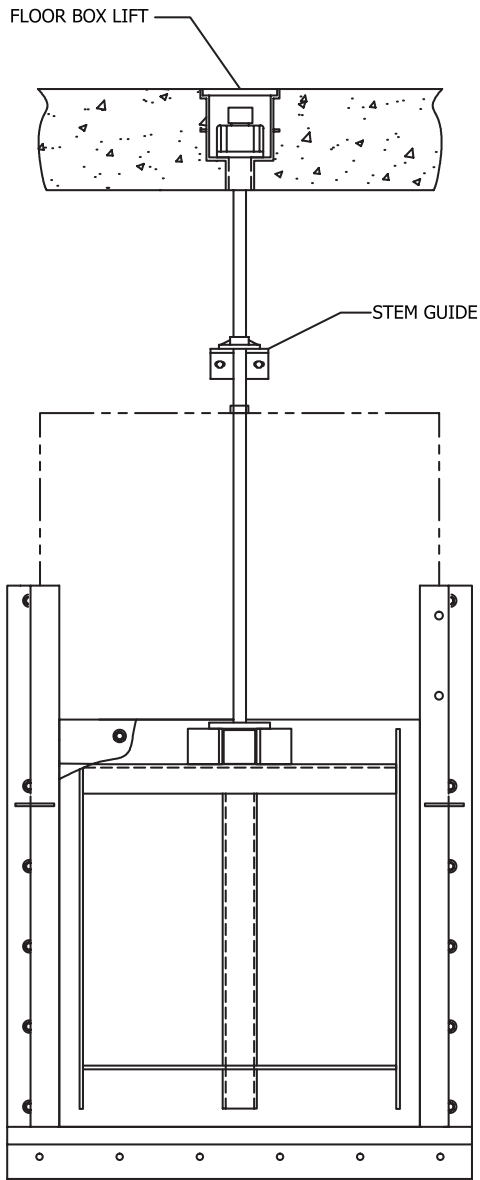

**NON-RISING STEM
SLIDE GATE**

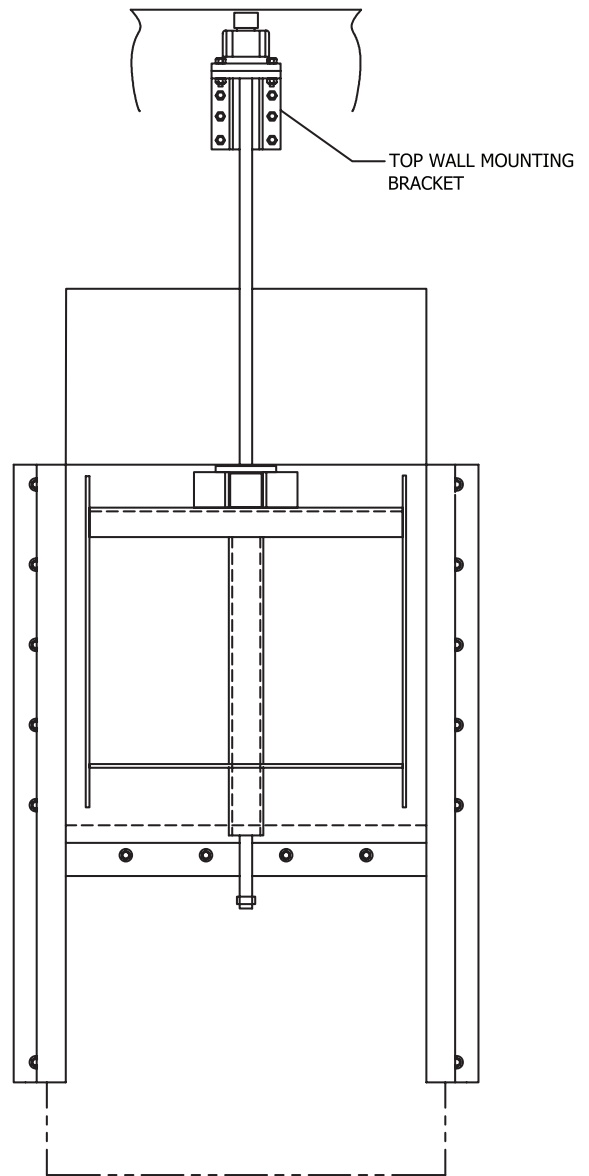

**NON-RISING STEM
SLIDE (WEIR) GATE**

GATE MOUNTING CONFIGURATIONS

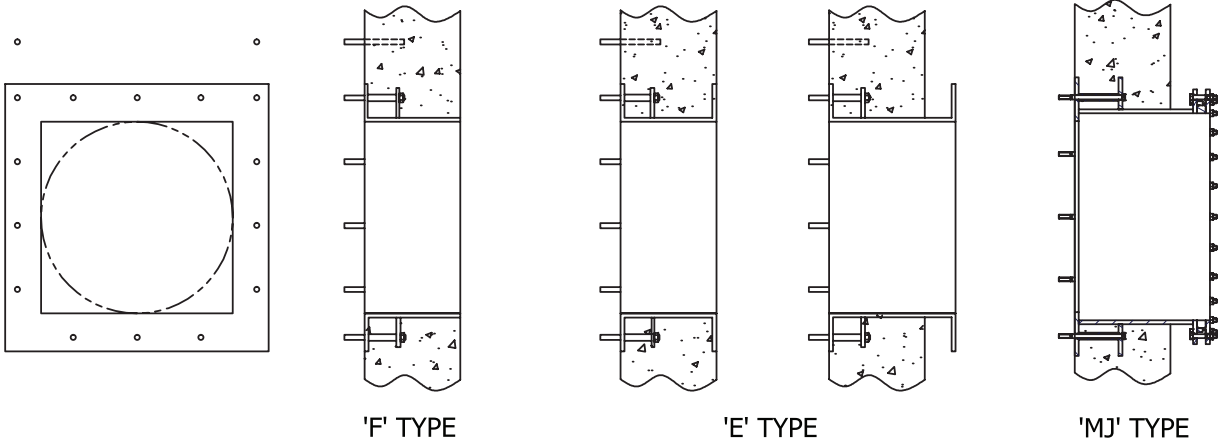

'F' TYPE

'E' TYPE

'MJ' TYPE

WALL THIMBLES

AVAILABLE WITH SQUARE, RECTANGLE OR CIRCULAR OPENING

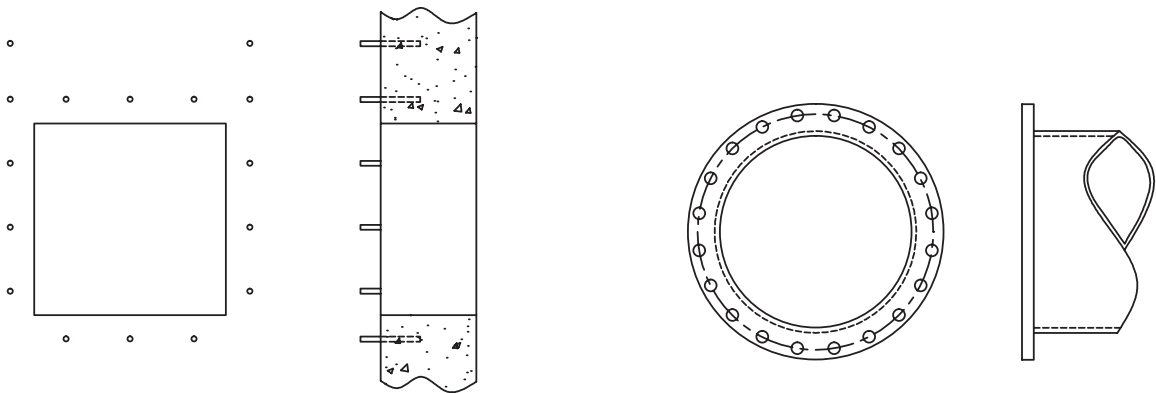

ANCHOR BOLT MOUNTING

PIPE FLANGE MOUNTING

SECTION _____

TYPICAL SPECIFICATIONS FOR SS-250 SERIES FABRICATED SLIDE GATE

PART 1 GENERAL

1.01 SCOPE OF WORK

- A. The equipment provided under this section shall be fabricated, assembled, erected, and placed in proper operating condition in full conformity with the drawings, specifications, engineering data, instructions, and recommendations of the equipment manufacturer unless exceptions are noted by the engineer.

Gates and operators shall be supplied with all the necessary parts and accessories indicated on the drawings, specified or otherwise required for a complete and properly operating installation, and shall be the latest standard product of a manufacturer regularly engaged in the production of fabricated water control gates.

- B. Unit Responsibility: To insure compatibility of all components directly related to the slide gates, unit responsibility for the slide gates, actuators and accessories as described in this section shall be the responsibility of the slide gate manufacturer unless specified otherwise.

1.02 SUBMITTALS

- A. Submittals shall be in accordance with Sections _____ and as specified herein.

Submittals shall include as a minimum:

1. Shop Drawings
2. Manufacturer's operation and maintenance manuals and information.
3. Manufacturer's installation certificate.
4. Manufacturer's equipment warranty.
5. Manufacturer's performance affidavit in accordance with Section _____.
6. Design calculations demonstrating lift loads and deflection in conformance to the application requirements.
Design calculations shall be approved by a licensed engineer (PE) and shall be available upon request.

1.03 QUALITY ASSURANCE

A. Qualifications

1. All of the equipment specified under this Section shall be furnished by a single manufacturer with a minimum of 20-years of experience designing and manufacturing slide gates. The manufacturer shall have manufactured stainless steel slide gates of the type described herein for a minimum of 20 similar projects.
2. The sealing system shall be certified and tested for operation and performance to leakage specifications compliant with AWWA C-561 for a minimum of 100,000 cycles.
3. The project design is based on the Waterman SS-250 Series Fabricated Slide Gate as manufactured by Waterman Valve of Exeter, California. Proposed alternates must be pre-approved, per addendum, at least 14-days prior to close of bid. Requests for alternates must be supplemented with detailed drawings, specifications, and references. Any/all additional costs for structure modifications or other changes associated with utilizing a brand other than Waterman are to be borne by the contractor.
4. To insure quality and consistency, the slide gates listed in this section shall be manufactured and assembled in a facility owned and operated by the slide gate manufacturer. Third-party manufacturers contracted for fabrication and assembly of the slide gates will not be permitted.

PART 2 EQUIPMENT

2.01 GENERAL

- A. The gates shall be either self-contained with yoke and bench stand operators, or non-self-contained with separate stem guides and operator, in accordance with the requirements of these specifications.
- B. The gates shall be compliant with the latest version of AWWA C561, as described below.
- C. Specific configurations shall be as noted on the gate schedule or as shown on the plans.
- D. Materials:

COMPONENTS	MATERIALS
FRAME, YOKE, COVER SLIDE, WALL THIMBLES	Stainless Steel ASTM A240, Type 304L Stainless Steel ASTM A240, Type 316L Stainless Steel ASTM A240, Type 2205 Duplex
SEAT/SEALS & STEM SLEEVES	Ultra-High-Molecular-Weight Polyethylene (UHMWPE) ASTM D4020
CORD SEAL	Neoprene ASTM D2000 Nitrile ASTM D2000 Viton ASTM D1418
FLUSH BOTTOM SEALS	Neoprene ASTM D2000 Viton ASTM D1418
STEMS	Stainless Steel ASTM A276, AISI Type 304 Stainless Steel ASTM A276, AISI Type 316 Stainless Steel ASTM A276, AISI Type 2205 Duplex Stainless Steel ASTM A564, AISI Type 630
STEM COVER	Clear Butyrate with Mylar Strip Galvanized A53 Steel Aluminum
STEM GUIDES	Cast Iron (ASTM 126 Class B) Bronze Bushed Cast Iron (with 2% Nickel) Bronze Bushed Ni-Resist Cast Iron (ASTM A436, Type 2 or 2B) Bronze Bushed Stainless Steel (ASTM A240 Type 304L) UHMW Bushed Stainless Steel (ASTM A240 Type 316L) UHMW Bushed Stainless Steel (ASTM A240 Type 2205) UHMW Bushed
WALL BRACKETS	Not Applicable Cast Iron (ASTM 126 Class B) Cast Iron (with 2% Nickel) Ductile Cast Iron (ASTM A536) Ni-Resist Cast Iron (ASTM A436, Type 2 or 2B) Steel (ASTM A36) Stainless Steel ASTM A240, AISI Type 304L Stainless Steel ASTM A240, AISI Type 316L Stainless Steel ASTM A240, AISI Type 2205
PEDESTALS	Not Applicable Cast Iron (ASTM 126 Class B) Cast Iron (with 2% Nickel) Ductile Cast Iron (ASTM A536) Ni-Resist Cast Iron (ASTM A436, Type 2 or 2B) Steel (ASTM A36/A53) Stainless Steel ASTM A240/A312, AISI Type 304L Stainless Steel ASTM A240/A312, AISI Type 316L Stainless Steel ASTM A240/A312, AISI Type 2205
FASTENERS AND ANCHOR BOLTS	Stainless Steel ASTM A593 & A594, Type 304 CW A193 & A194 Stainless Steel ASTM A593 & A594, Type 316 CW A193 & A194 Stainless Steel ASTM A593 & A594, Type UNS S-32205 Duplex 2205
FINISH	Polyamide Epoxy Coal Tar Epoxy

E. GATE SCHEDULE

EQUIPMENT NUMBER	GATE SIZE, INCH ¹	GATE TYPE ²	OPENING DIRECTION ³	BOTTOM SEATING ⁴	DESIGN HEAD, FEET		OPERATOR TYPE
					SEATING	UNSEATING	

Notes: Clear opening width by height. E = embedded frame, W = wall mounted, Y = self-contained, F = flatback U = upward, D = downward FB = flush bottom

2.02 FRAME AND GUIDE RAILS

- A. The gate frame shall be composed of stainless steel guide rails with UHMW seat/seals upstream and downstream. The seat/seals shall form a tight seal between the frame and the slide (disc). The guides will be of sufficient length to support ½ the height of the slide when in the full open position.
- B. Yoke shall not deflect more than 1/360th of the span under full head break load.
- C. Seals shall be replaceable without removing the frame from the wall. In the case of embedded gates, they shall be constructed in a manner that allows replacement of the seals without removal of the gate frame from the embedment.

2.03 STEM AND STEM GUIDE

- A. Material
 1. The stem shall be solid stainless steel of the specified grade.
- B. Design
 1. Guides shall be adjustable with split stem sleeves. Guides shall be spaced per the manufacturer's recommendations. The stem L/r ratio shall not exceed 200.
 2. Stem threads shall be machine cut 29 degree full Acme or stub Acme type.
 3. Nominal diameter of the stem shall not be less than the crest of the threaded portion.

2.04 SEALS

- A. The seals shall be self-adjusting. Seals requiring periodic maintenance and adjustments to maintain specified leakage rates will not be permitted.
- B. The top seal design on upward opening gates consisting of four side seals shall incorporate a self-cleaning wiping function that prevents debris from building-up above the top seal and causing premature wear of the seats, seals, and gate face.
- C. The UHMW seats shall impinge on the slide (disc) by way of a continuous loop cord seal. Seal designs incorporating resilient seals such as "J-bulb" or "P" seals that come in direct contact with the friction surface of the slide will not be considered.
- D. The cord seal shall function as a seal between the frame and the UHMW, and as a spring force to maintain contact between the UHMW and the slide (disc).
- E. The resilient bottom seal shall be set into the invert member of the frame which shall be formed in a manor to protect 3 sides of the seal only exposing the side that will come in contact with the slide. Disc-mounted invert seals exposing additional surface area will not be permitted.
- F. The self-adjusting seal system shall provide an allowable leakage rate of no more than ½ AWWA leakage rate per minute per peripheral foot of perimeter opening for seating and unseating heads.

2.05 SLIDE COVER (DISC)

- A. The slide cover (disc) shall be stainless steel plate reinforced with structural shapes welded to the plate.
 - 1. The slide cover shall not deflect more than 1/720th of the span, or 1/16" at the seated sealing surface of the gate under maximum specified head.
 - 2. The stem to gate connection shall be either the clevis type, with structural members welded to the slide and a bolt or bolts to act as a securing method, or a threaded and bolted (or keyed) thrust nut supported in a welded nut pocket.
 - 3. The clevis, or pocket and yoke, of the gate shall be capable of taking, without damage, at least twice the rated thrust output of the operator at 40 pounds of pull on a hand wheel or hand crank, and at locked-rotor stall of a motor operator.
 - 4. The slide cover shall be constructed with vertical and horizontal reinforcement ribs.
 - 5. All welds shall be performed by an AWS-certified welding technician.

2.06 ANCHOR BOLTS

- A. Anchor hardware shall be provided by the slide gate manufacturer.
 - 1. The size, quantity, and location of the anchor hardware shall be engineered by the slide gate manufacturer. Upon client request manufacturer shall provide calculations for anchor bolt sizing and quantity.
 - 2. Anchor hardware consisting of studs, nuts and washers shall be provided by the manufacturer.

PART 3 EXECUTION

3.01 INSTALLATION

- A. Installation of the gates shall be performed in accordance with standard industry practices. It shall be the responsibility of the CONTRACTOR to handle, store, and install the equipment specified in this Section in strict accordance with the Manufacturer's recommendations.
- B. The CONTRACTOR shall review the installation drawings and installation instructions prior to installing the gates.
- C. The gate frames shall be installed in a true vertical plane, square and plumb, with no twist, convergence, or divergence between the vertical legs of the guide frame.
- D. The CONTRACTOR shall fill any void between the guide frames and the structure with non-shrink grout as shown on the installation drawing and in accordance with the grout manufacturer's recommendations.
- E. The frame cross rail shall be adjusted as required to maintain consistent seal compression across the full width of the gate.

3.02 FIELD TESTING

- A. After installation, all gates will be field tested in the presence of the ENGINEER and OWNER to ensure that all items of equipment are in full compliance with this Section. Each gate assembly shall be water tested by the CONTRACTOR at the discretion of the ENGINEER and OWNER, to confirm that leakage does not exceed the specified allowed leakage.

INNOVATIONS IN WATER CONTROL

Waterman Industries is a leading supplier of water control products to the water treatment, rural water distribution, industrial processing and agricultural industries based in Exeter, California.

The company was founded by W.A. Waterman in 1912 as a fabricator of metal components for the growing California Central Valley agricultural markets. Waterman's purchase of the Red Top line in the early 1930's gave the company a leading position in both agricultural water distribution and on-farm water management products.

Herrick Waterman became company President in 1953, and rapidly expanded the company into production of large and complex sluice gates, slide gates and radial gates for water projects throughout the Western States. A new plant was opened in 1963 to support - growth from projects worldwide. The company remains one of North America's leading suppliers of gates for municipal water treatment and rural water distribution systems.

Beyond best-in-class products, Waterman Industries is also known as a leader in outstanding customer service, product training, and technical support.

In 2018, Waterman was acquired by McWane, Inc. McWane, Inc. is a family-owned business based in Birmingham, Alabama, with companies across the United States and the world. At the McWane Family of Companies, we cast ductile iron products—including pipe, valves, hydrants, fittings, and plumbing products—manufacture fire extinguishers, fire suppression systems, steel pressure vessels, build network switches and monitoring equipment. We are the leader in delivering clean, safe drinking water around the world while focusing on the safe, environmentally-friendly manufacturing of our products. The company employs more than 6,000 team members and has a longstanding commitment of support to the communities where we live and work.



Waterman Valve LLC - Engineered Water Control Products Since 1912
25500 Road 204 Exeter, California 93221 USA Tel: 1-(559) 562-4000 Fax: 1-(559) 562-2277 www.WatermanUSA.com
Design and Specification Support: (800) 445-8457