

WALL THIMBLES

Why Wall Thimbles Are the Preferred Method to Mount a Gate

KEY BENEFITS:

- Pre-positions and aligns proper mounting location for gate. Provides a flat mounting surface.
- Eliminates time spent placing and drilling anchors – exact alignment occurs automatically with pre-drilled thimble holes. No errors or accidental deflection from improper anchor spacing.
- Provides an “engineered”, optimum anchor pattern with correct size and placement of anchors, critical in high head applications.
- Eliminates need for grouting behind gate – and potential for grout to foul gate seats.
- Creates proper opening during pour.
- Forms transition, where needed, from pipe on one side of wall with gate on other.
- Allows gate to be removed and reinstalled easily.

DESCRIPTION:

In most installations, mounting a gate to a cast-in-place wall thimble will lead to superior results. Wall thimbles are widely used with cast-iron sluice gates. They can also be used with fabricated slide gates, particularly in high-head applications.

Thimbles are typically a solid cast iron piece positioned into the wall structure before the concrete wall is poured. It provides the fixed dimensional opening through the wall, in addition to an accurate machined mounting surface for the gate. Holes are factory-drilled and tapped in the thimble flange to match exactly to the gate frame mounting dimensions.

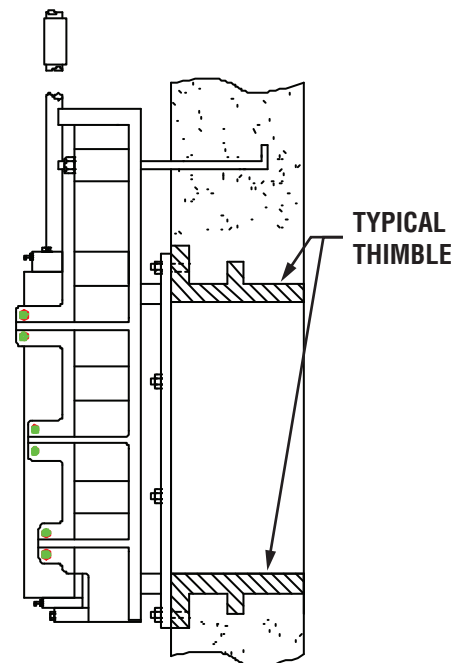
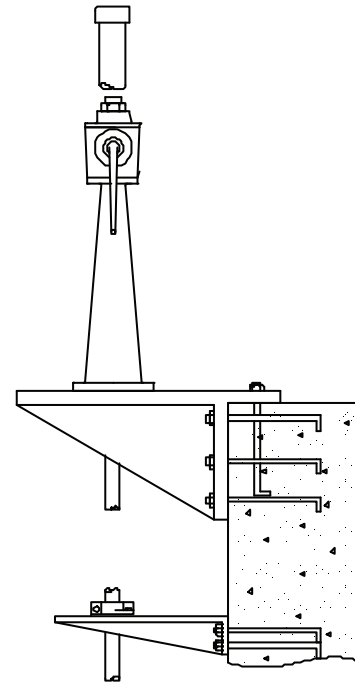

WALL THIMBLES

Because a thimble is an entirely separate part, it can be shipped prior to the gate so that it added before the concrete is poured. The thimble makes mounting a gate easier. The gate is quickly plumb and parallel, with the possibility of distortion minimized.

The use of thimbles offers considerable advantage to the engineer, contractor, or owner. Since most anchor bolts are omitted, time is saved, accuracy is enhanced, and form work is reduced. Often the cost of a thimble is easily justified with lower labor cost and additional peace-of-mind. Additionally, thimbles can be shipped early for inclusion in the construction forms, accelerating the job progress and eliminating the need for extra jobsite forming of the opening through the wall.

Overall construction costs may be reduced, installation time is lessened, a rigid machined surface is provided, and dependency upon the expertise of the installer is not as crucial. When a thimble is used, gates can be removed and installed again without disturbing the concrete. Future gate locations can also be planned with pre-installed thimbles matched to blind plates.

STYLES / TYPES OF THIMBLES OFFERED:

Thimble types are named for the casting cross section shape. Each type has its own application, and remains the same even though the size and depth of thimble may vary. The illustrations indicate the most popular types and their particular application.

“F” THIMBLE (STANDARD)

The “F” type wall thimble is the most widely used for mounting sluice or flap gates which are subject to any seating pressure and moderate unseating pressure. As is shown, the “F” thimble has a flange for mounting the gate on one side only. The small inner staff of the “F” thimble provides both a cleat for holding the thimble more securely in the wall and a water stop to prevent “end run” seepage. The end opposite the flange merely forms the opening to the other side of the wall or bulkhead.

“E” THIMBLE (HIGH HEAD)

The “E” type wall thimble is similar to the “F” thimble except that it has a flange on both ends. It is required for sluice gates subjected to high unseating heads, severe conditions, and when extension, another type flange, trash racks, or flap gates may be added to the back of the thimble. As with the “F” type thimble, the small inner staff of the “E” provides both a holding cleat and a water stop. The back side of a Type E thimble can also be drilled to accommodate connection to flanged pipe.

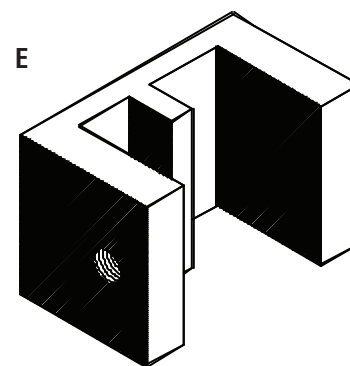
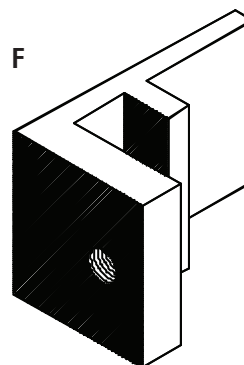

WALL THIMBLES

“MJ” THIMBLE

The Mechanical Joint type wall thimble has a standard flange on one end and a mechanical joint type flange on the other. It is the most widely used for direct connection to pipeline or penstock without requiring a flange on the pipe end. The “mechanical joint” employs a following ring around the pipe which is cinched to a minor bolt flange on the thimble end. In cinching the ring a rubber gasket is squeezed between the tapered end of the thimble and he pipe, thus holding the pipe into the thimble end through friction, as well as providing a seal.

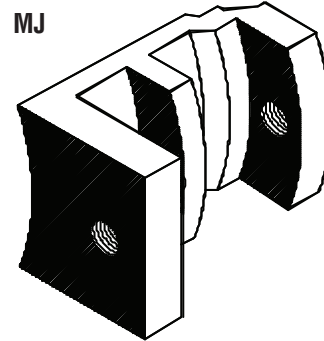

THIMBLE SPECIFICATIONS AND INSTALLATION:

Wall thimbles shall be heavy, one piece castings. The front flange shall be machined to a plane and shall be drilled and holes tapped to mate the drilling pattern of the gate frame. Holes shall be plugged as to prevent concrete from intruding into threaded area. The vertical centerline shall be clearly shown by permanent marks at the top and bottom of the machined face. The word “top” shall be marked permanently near the top center-line of the thimble opening. The surfaces to be cast into the concrete shall be free of paint, oil, and grease. Corrosion-resistant studs and nuts shall be provided for attaching the gate. Mastic is recommended to form a seal between the front face of the thimble and the back of the gate frame. Gate frame and thimble should be tightened for metal to metal contact, squeezing mastic to a thin film for a watertight joint. Standard lengths to match to the structure are 12” and 18”.